

PARTS LIST

Remote Engine Starter Unit Kit P/N 08E91-E54-100

Transmitter

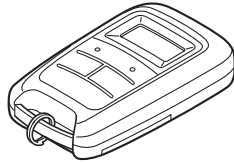

Control unit

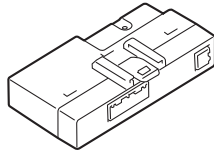

Antenna

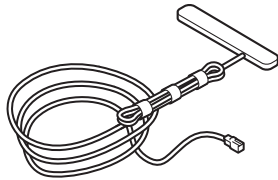

ID label



Remote Control Engine Starter Attachment Kit P/N 08E92-TR0-100B

Engine starter harness

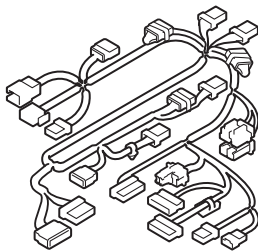

Control unit bracket

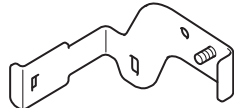

3 Relays

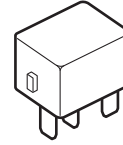

Flange nut



20 Wire ties

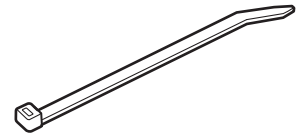

3 Long wire ties

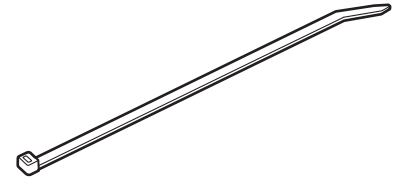

9 Urethane tapes

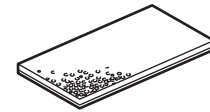

Clip

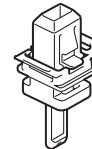

Caution label



Fuse label

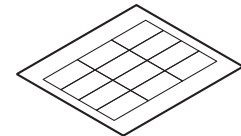

Accessory User's Information Manual

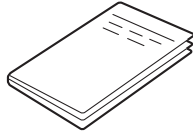

Quick start guide

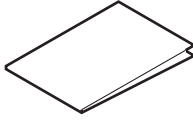

TOOLS AND SUPPLIES REQUIRED

Flat-tip screwdriver
Phillips screwdriver
Ratchet
10 mm Socket
10 mm Open end wrench
Isopropyl alcohol
Shop towel
Tape measure
Scissors
HDS/MVCI
Masking tape
Diagonal cutters
Ruler
Tape

The following tools are available through the Honda Tool and Equipment Program. On the iN, click on: Service > Service Bay > Tool and Equipment Program, then enter the number under "Search". Or, call 888-424-6857.

- Trim Tool Set (T/N SOJATP2014)
- Plastic Trim Tool (T/N SILTRIMTL10)

Illustration of the Remote Control Engine Starter in the Vehicle

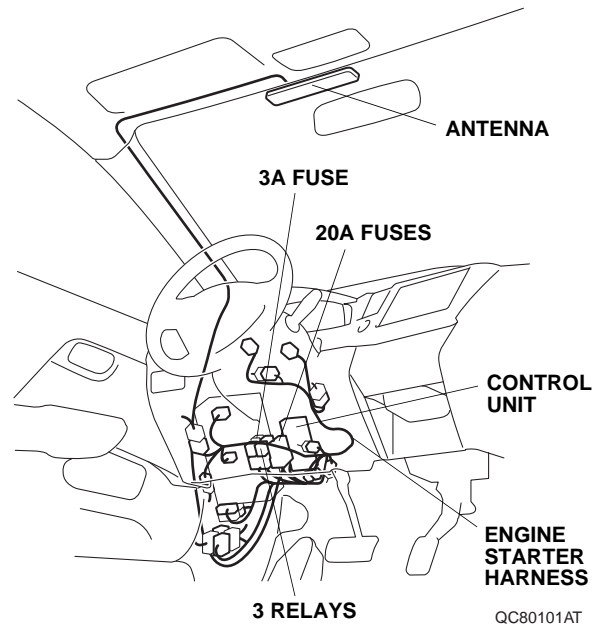

INSTALLATION

Customer Information: The information in this installation instruction is intended for use only by skilled technicians who have the proper tools, equipment, and training to correctly and safely add equipment to your vehicle. These procedures should not be attempted by "do-it-yourselfers."

1. Disconnect the negative cable from the battery.

- Using isopropyl alcohol on a shop towel, clean the area where the ID label will attach.

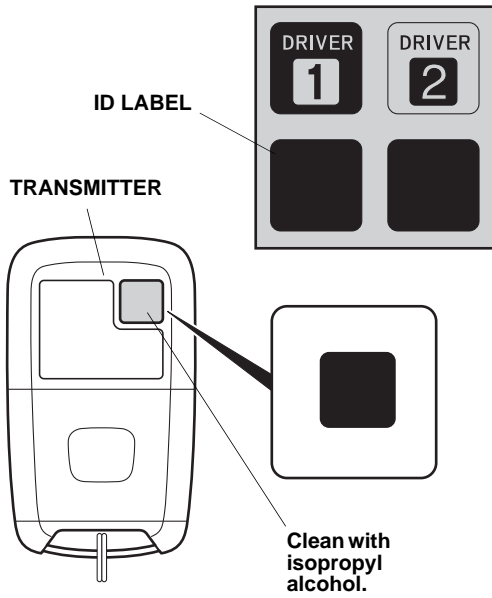

QB32111CH

- Attach the blank ID label to the transmitter in the area as shown.
- Remove the left and right lenses from the map light console (four retaining tabs for each lens). Remove two bolts.

With Moonroof: Remove the map light console. Then unplug three vehicle connectors, and remove the switch (four retaining tabs).

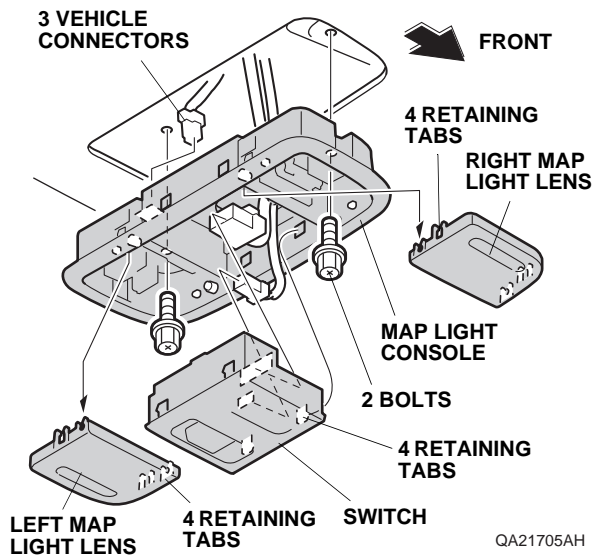

QA21705AH

Without Moonroof and With Hands Free Link: Remove the map light console (unplug two vehicle connectors).

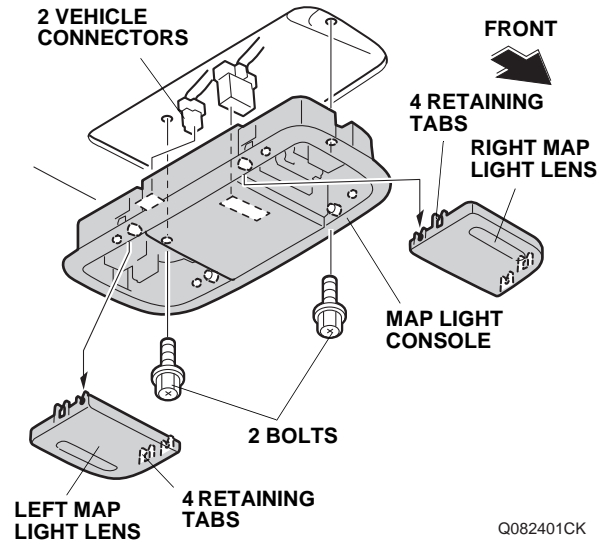

Q082401CK

- Remove the driver's and passenger's sunvisor holders.

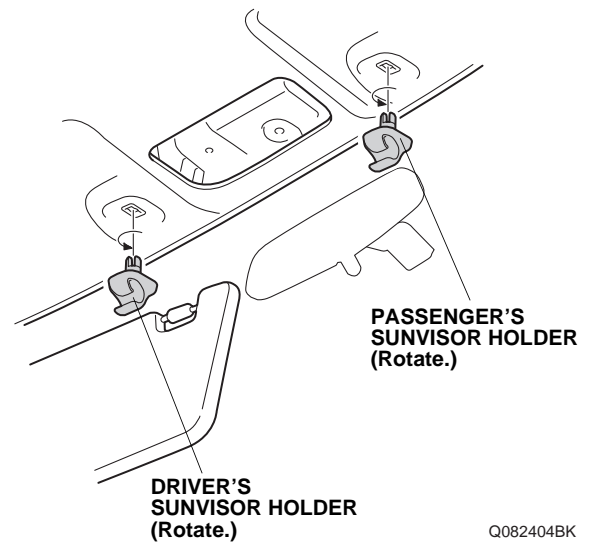

Q082404BK

- Wrap the end of a flat-tip screwdriver with tape. Locate the slot in the bracket cover, and insert a flat-tip screwdriver into the slot. Push the hook with the flat-tip screwdriver.

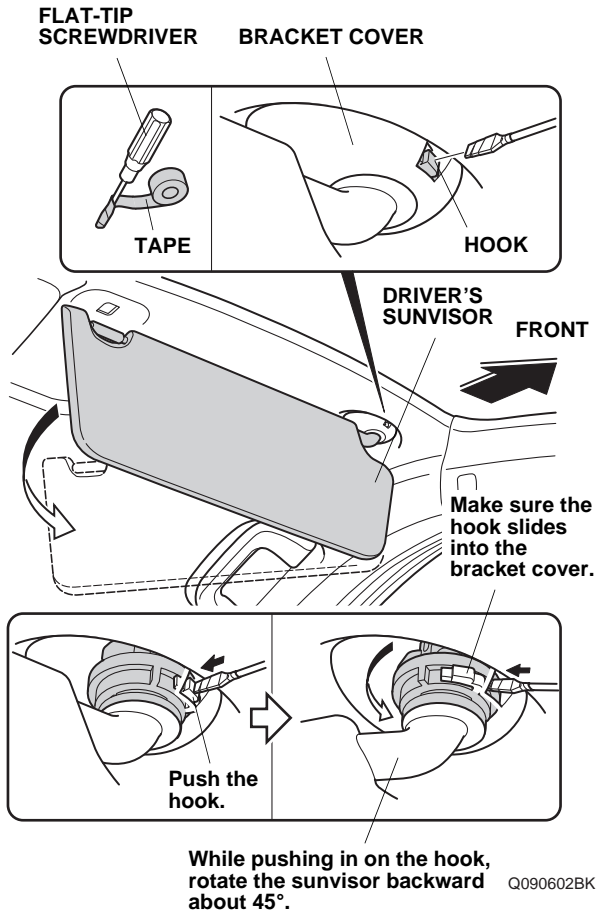

- While pushing in on the hook, rotate the driver's sunvisor backward about 45°. Make sure the hook slides into the bracket cover.
NOTE: If the hook did not stay pushed in, return the driver's sunvisor to its original position and repeat steps 6 and 7.

- Remove the driver's sunvisor.

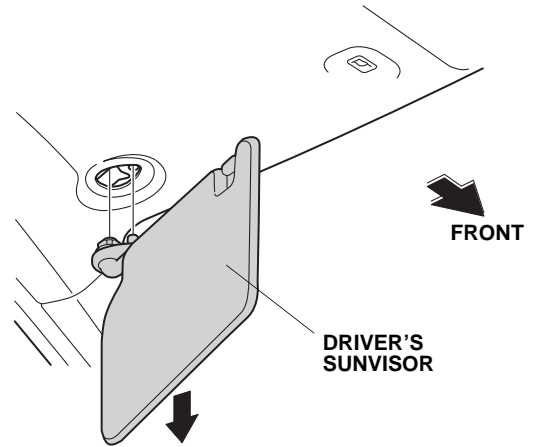

Q090603AK

- Pull away the driver's door opening seal.

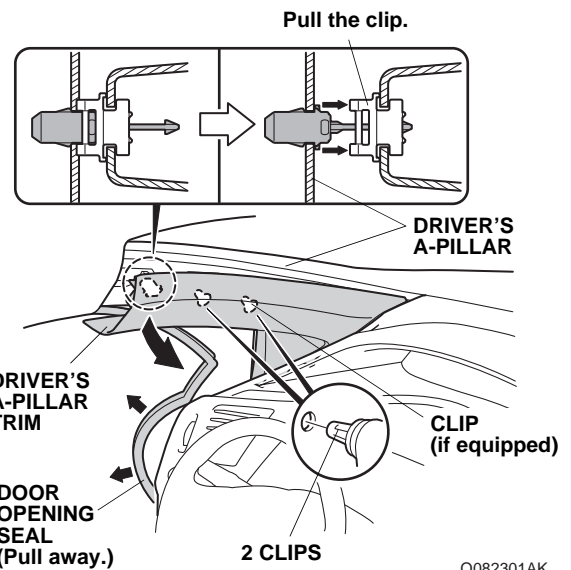

- Pull out the driver's A-pillar trim to release the clips.

- Put a shop towel in the opening between the driver's A-pillar trim and the driver's A-pillar to prevent dropping the A-pillar clips. Take care not to damage the driver's A-pillar trim.

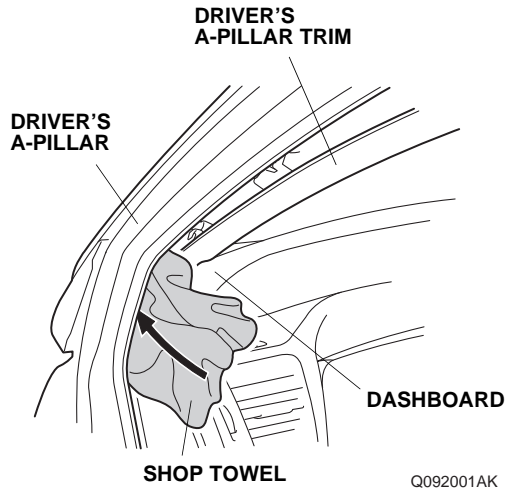

- Remove the driver's A-pillar trim from the upper clip (unplug the vehicle connector, if equipped). Carefully remove the shop towel and any clips that fell from the driver's A-pillar trim.
NOTE: The upper clip will stay in the body.

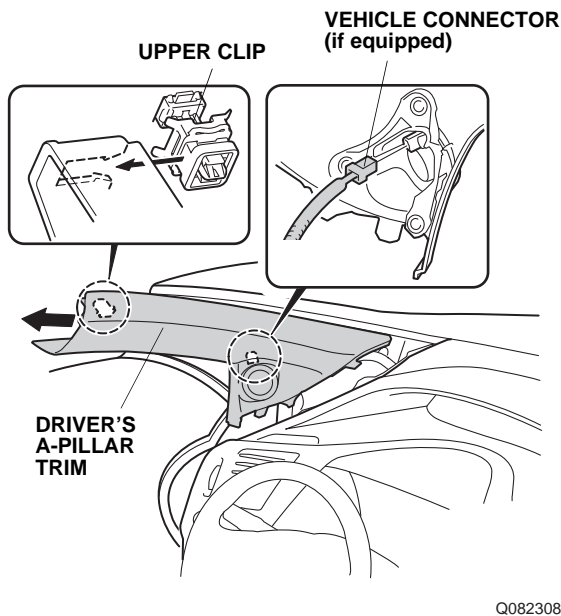

- Remove the remaining upper clip from the driver's A-pillar.

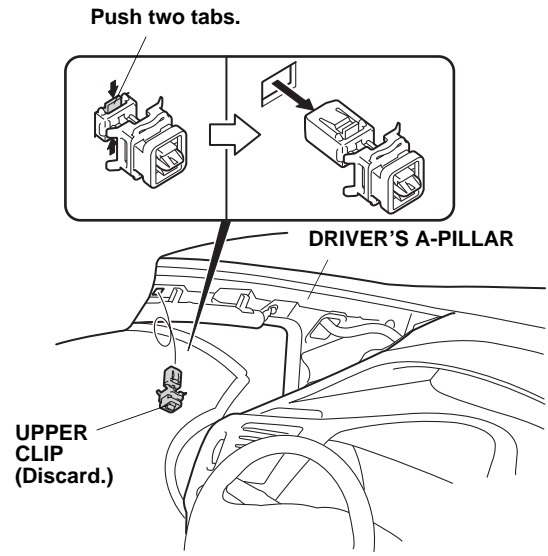

- Install the new clip (supplied) to the driver's A-pillar trim.
NOTE: When reinstalling the A-pillar trim, refer to the Service Manual for the correct overlap procedure.

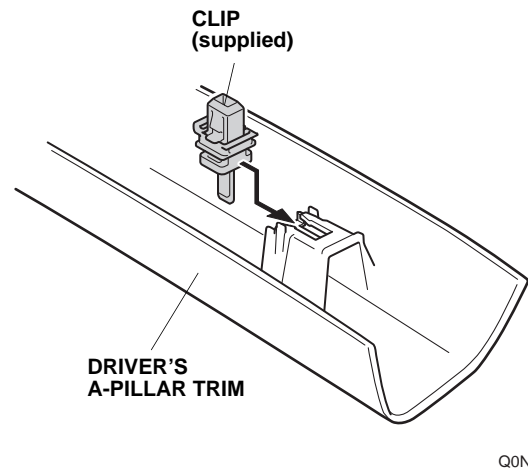

15. Remove the driver's dashboard lower cover (nine clips and unplug vehicle connectors).

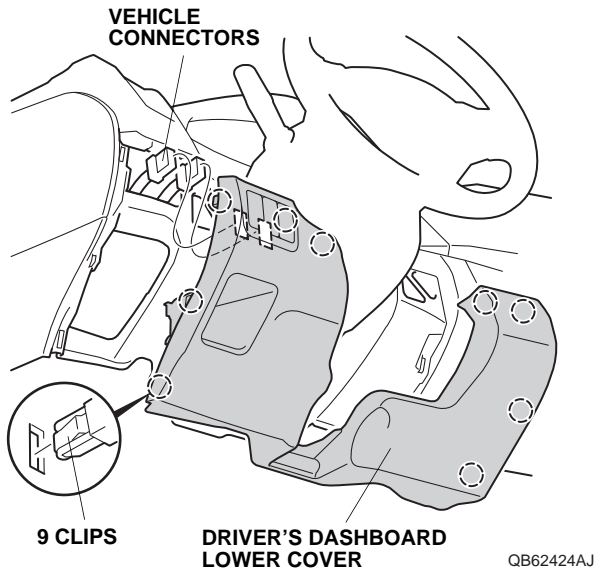

16. Remove the trunk lid/fuel fill door opener cover (four retaining tabs and two hooks). Remove one self-tapping screw. Using the key, unlock the trunk opener.



17. Remove or release the driver's front door sill trim.
4-Door: six clips, two hooks, and four retaining tabs.

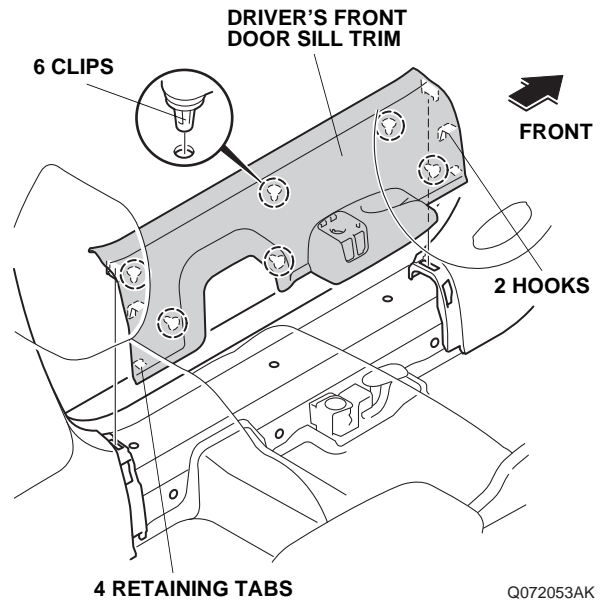

- 2-Door: seven clips, one hook, and two retaining tabs.

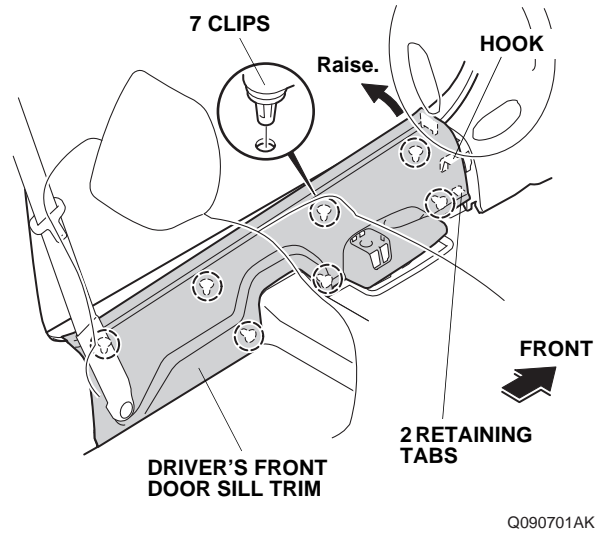

18. Pull away the door opening seal, and remove the driver's kick panel (two clips).

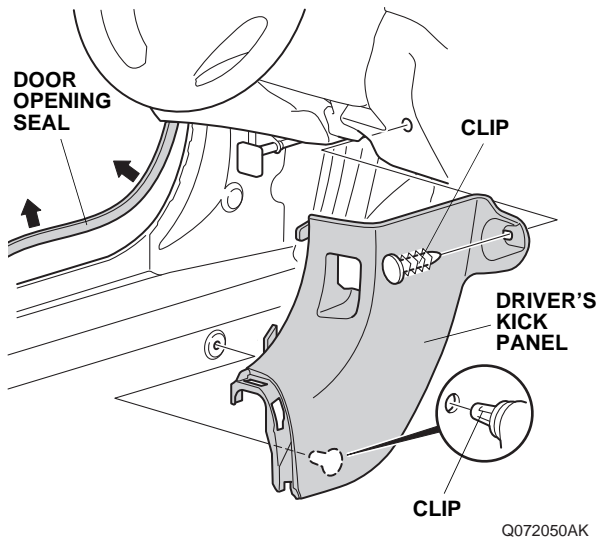

19. Lower the tilt lever, and turn the steering wheel 90° counterclockwise.

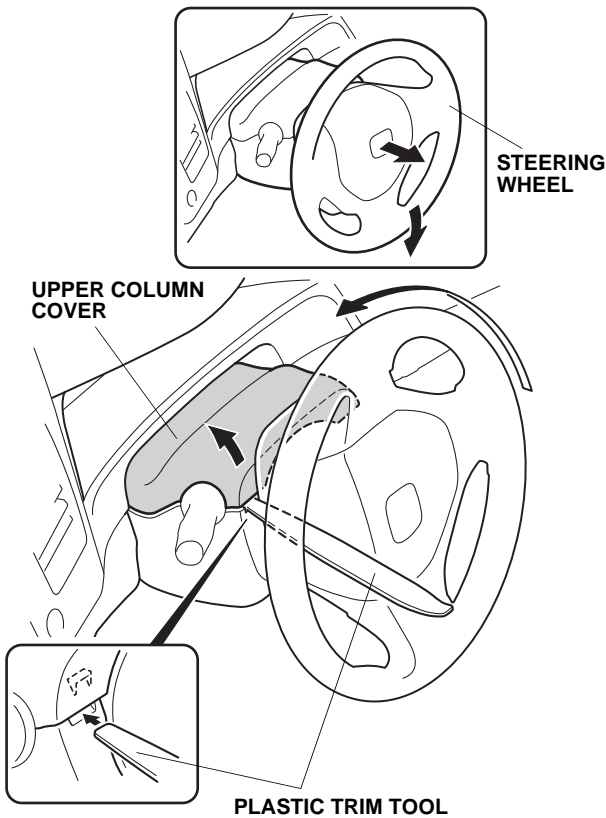

20. Using a plastic trim tool, release the lock tab as shown.

21. Turn the steering wheel 180° clockwise.

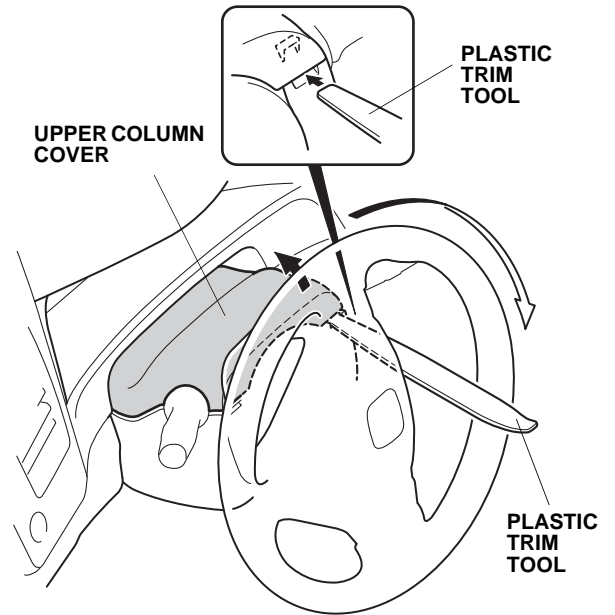

22. Using a plastic trim tool, release the lock tab on the other side the same way.

23. Remove the upper column cover (four hooks).

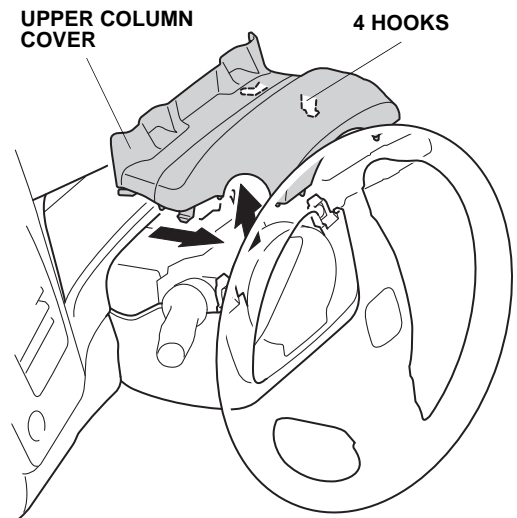

24. Remove two self-tapping screws from the lower column cover.

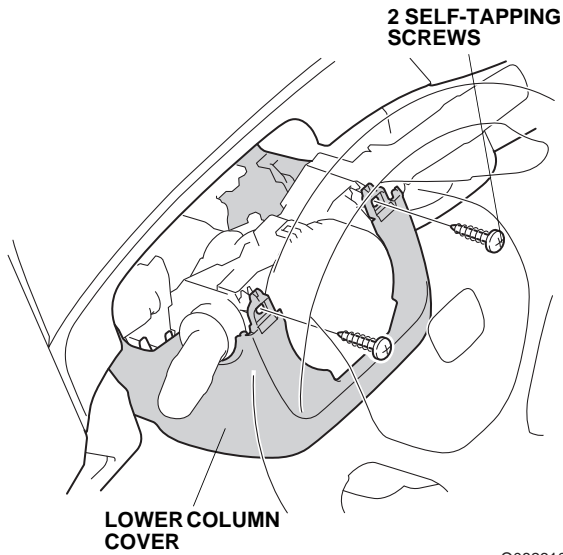

25. Remove the lower column cover (one self-tapping screw).

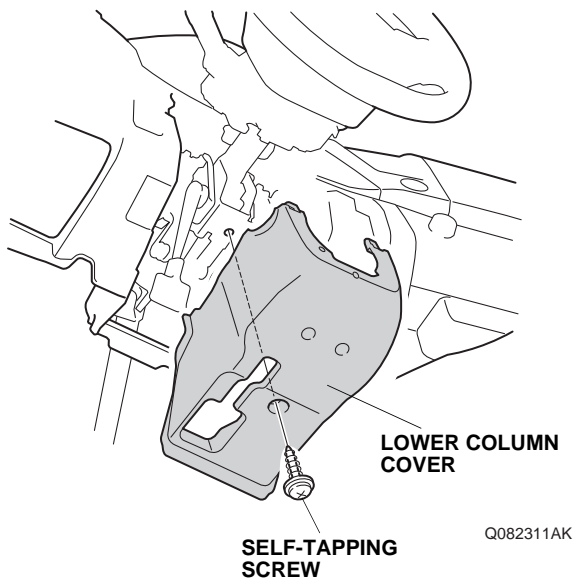

Installing the Antenna

26. Using scissors, cut one urethane tape in half. Wrap two halves of urethane tape to the antenna cable as shown.

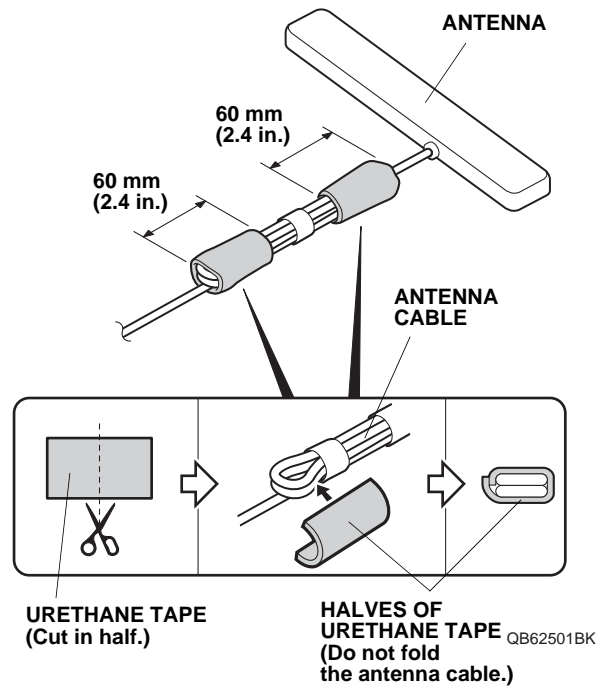

27. Using scissors, cut one urethane tape in half. Starting near the antenna end of the cable, wrap two halves of urethane tapes around the antenna cable at the measurements shown.

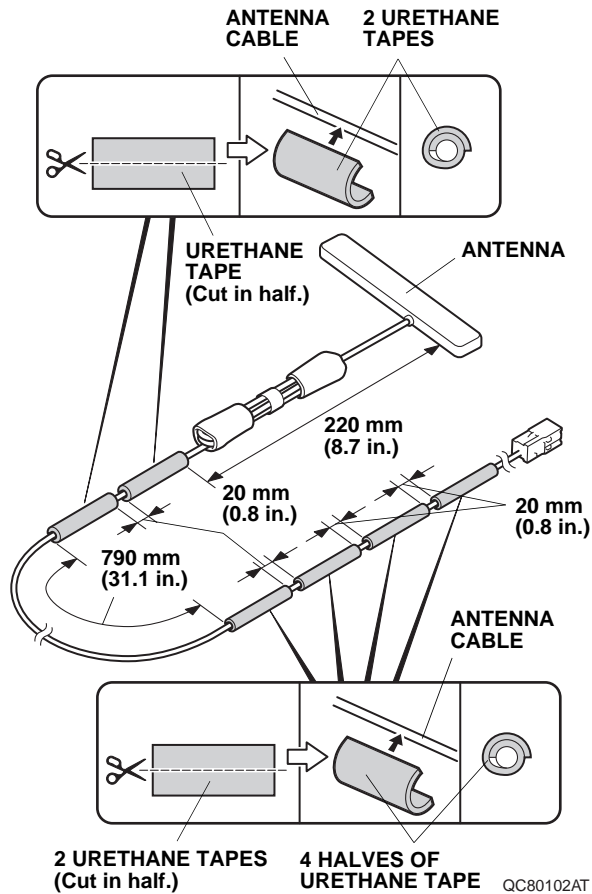

28. Using scissors, cut two urethane tapes in half. Wrap four halves of urethane tape around the antenna cable at the measurements shown.

29. Attach the antenna.

- Attach masking tape to the windshield at the measurement shown.

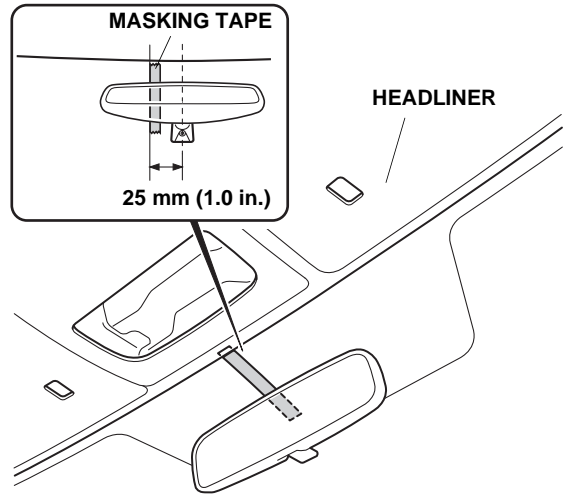

QB62018AK

- Fold the adhesive backing of the antenna as shown.

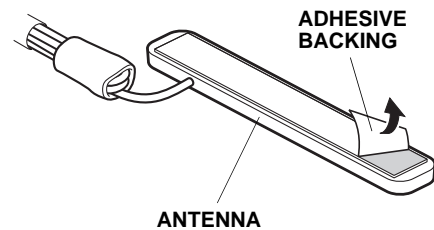

QB51401CH

- Using isopropyl alcohol on a shop towel, clean the windshield where the antenna will attach.
- Attach the antenna with masking tape. Adjust the position of the antenna so there is equal spacing on both sides.

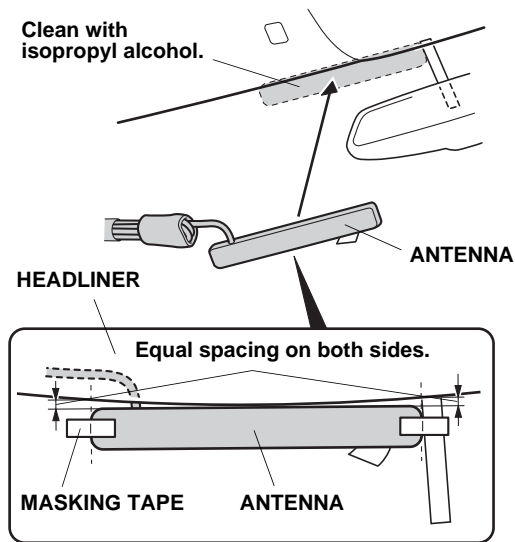

QB51404CH

- Carefully remove the adhesive backing from the antenna, and attach the antenna to the windshield. Press and hold the antenna firmly in place for 30 seconds.
- Remove the masking tape.

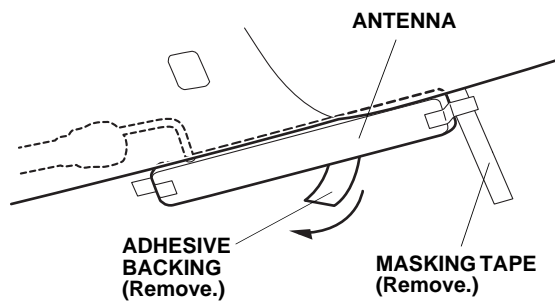

QB51405CH

30. Gently pull down the headliner, and tuck the antenna cable under the headliner. Be careful not to crease the headliner.

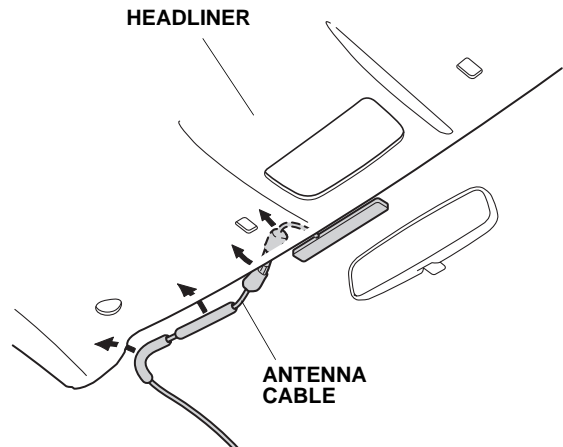

QB62502BK

31. Route the antenna cable down the A-pillar as shown. Using five wire ties, secure the antenna cable to the vehicle harness.

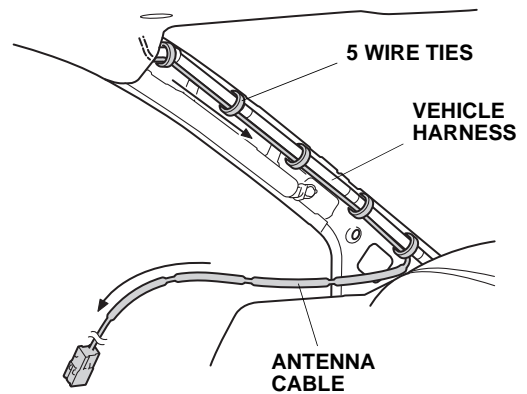

QB62002AK

32. Using isopropyl alcohol on a shop towel, clean the area where the urethane tape will attach.

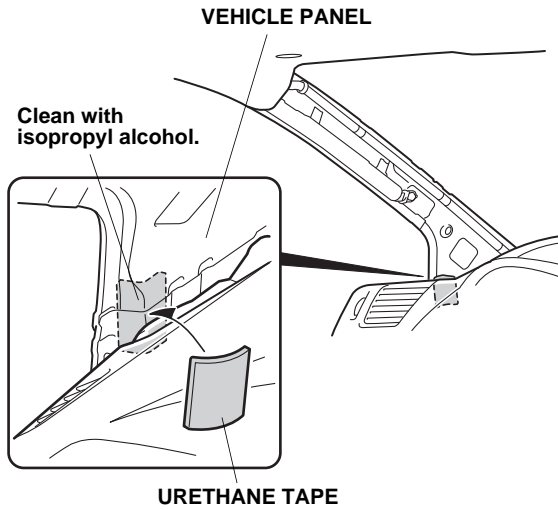

Q071304BK

33. Attach the urethane tape to the vehicle panel.
34. Pull away the door opening seal. Route the antenna cable down next to the dashboard, and tuck the antenna cable between the driver's A-pillar and the dashboard. Reinstall the door opening seal.

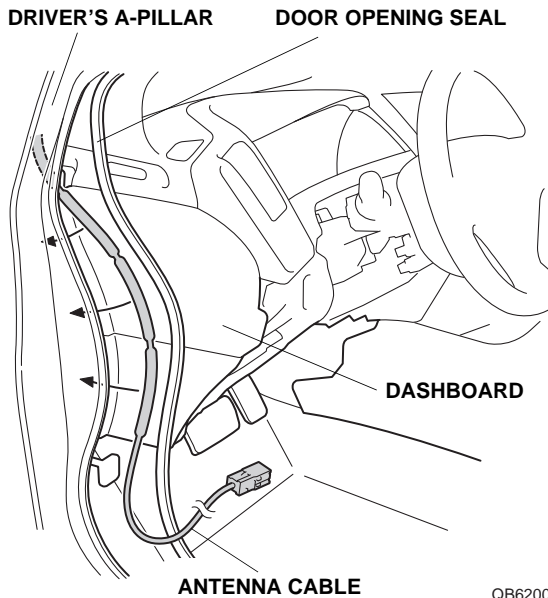

QB62003AK

Routing the Engine Starter Harness

35. Install three relays to the engine starter harness relay blocks.

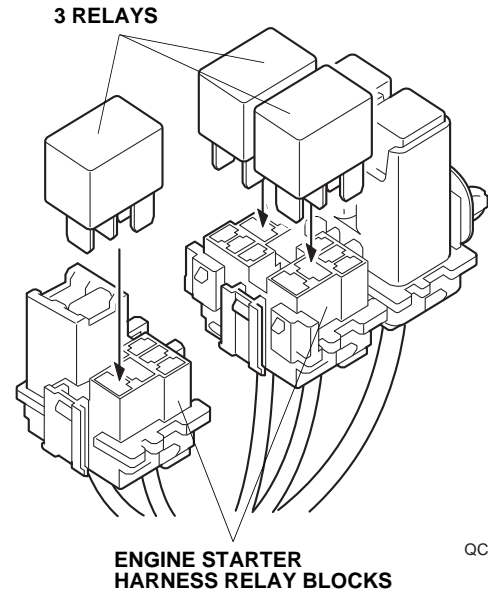

QC80103BT

36. Using isopropyl alcohol on a shop towel, clean the areas where the fuse labels will attach.

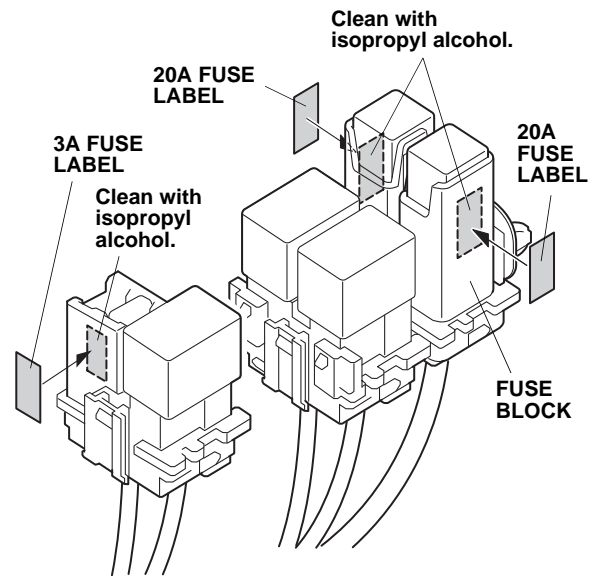

QC80104CT

37. Attach two 20A fuse labels and one 3A fuse label to the engine starter harness fuse block.

38. Plug the engine starter harness 28-pin connector into the control unit.

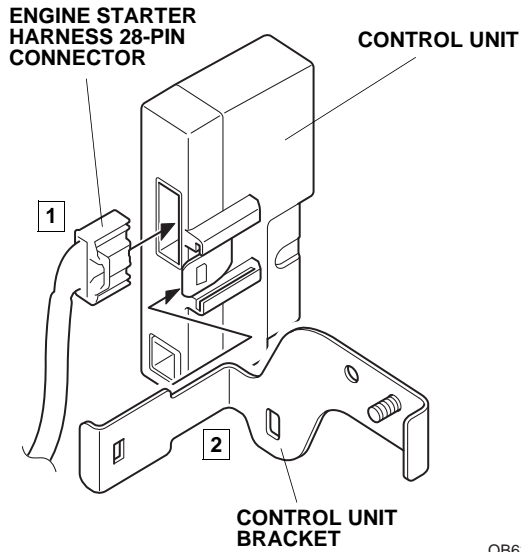

QB62004AK

39. Install the control unit bracket to the control unit.
40. Remove the data link connector (six retaining tabs).

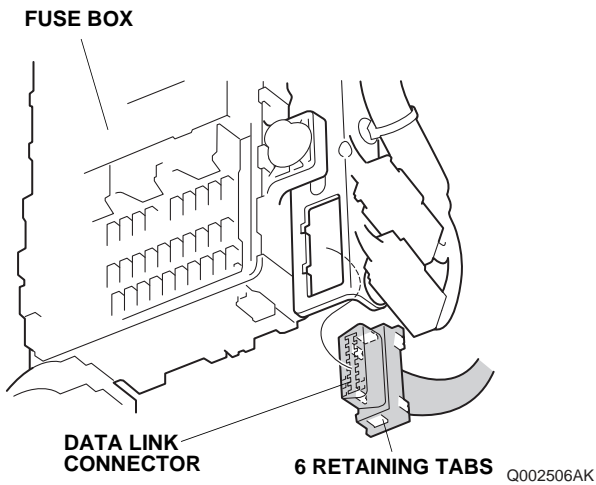

Q002506AK

41. Remove the vehicle harness clip from the vehicle frame.

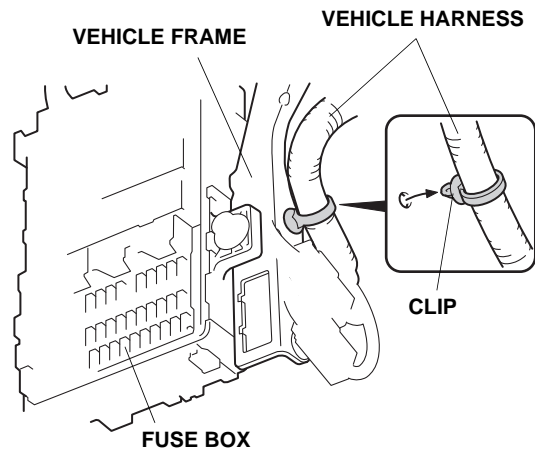

QC80132AT

42. Using the flange nut, secure the control unit bracket to the vehicle frame.

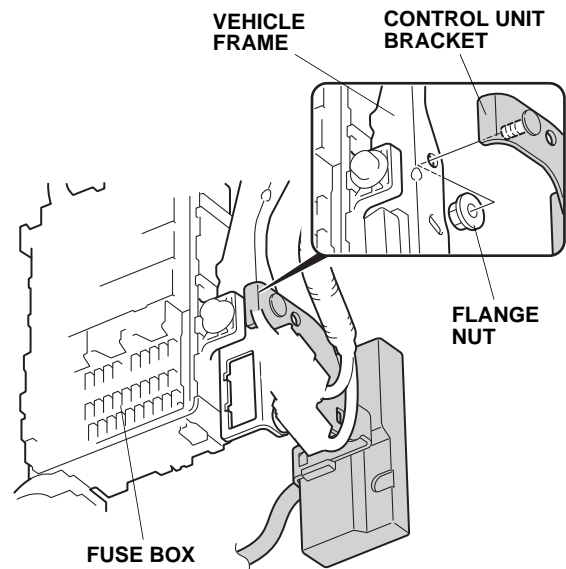

QC80134AT

43. Reinstall the data link connector.

44. Secure the vehicle harness to the control unit bracket hole.

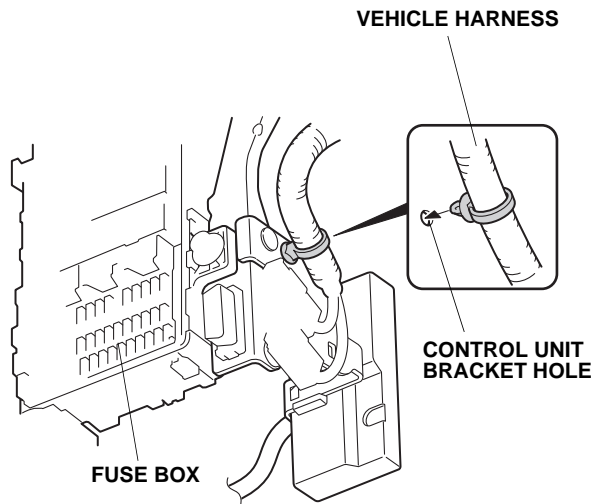

QC80133AT

45. Attach the engine starter harness relay block to the engine starter harness relay block as shown.

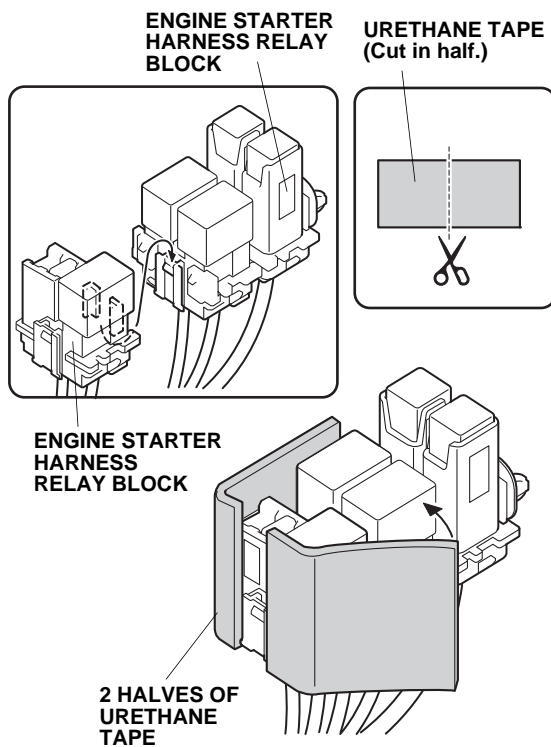

QC80105BT

46. Using scissors, cut one urethane tape in half. Attach two halves of urethane tape to the engine starter harness relay block.

47. Attach the engine starter harness relay blocks to the control unit bracket.

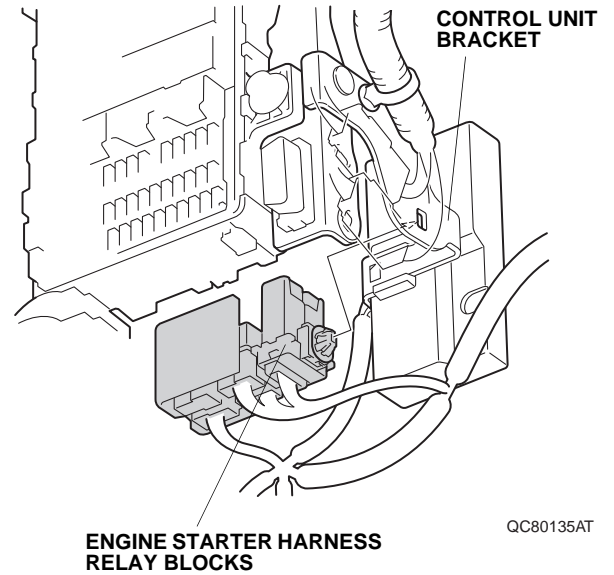

QC80135AT

48. Align the white tape on the engine starter harness with the clip on the vehicle harness, and secure the engine starter harness to the vehicle harness using one wire tie.

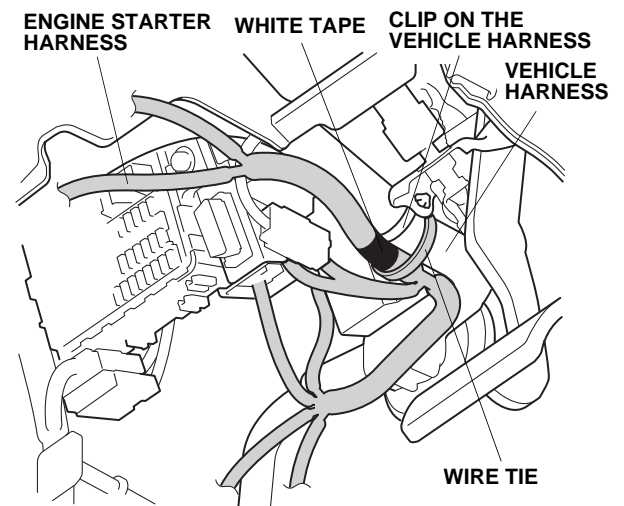

Q082602BK

- If the vehicle is equipped with an accessory door sill trim, continue with step 49; otherwise, go to step 54.

With Accessory Door Sill Trim

49. Remove the connectors from the bottom of the fuse box as shown.

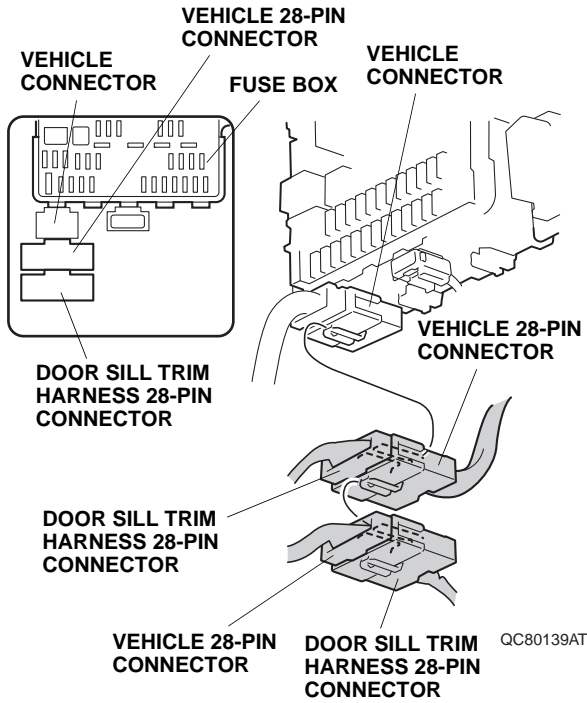

50. With moonroof model: Unplug the door sill trim harness 28-pin connector, and plug it into the engine starter harness 28-pin connector. Plug the remaining engine starter harness 28-pin connector into the vehicle 28-pin connector.

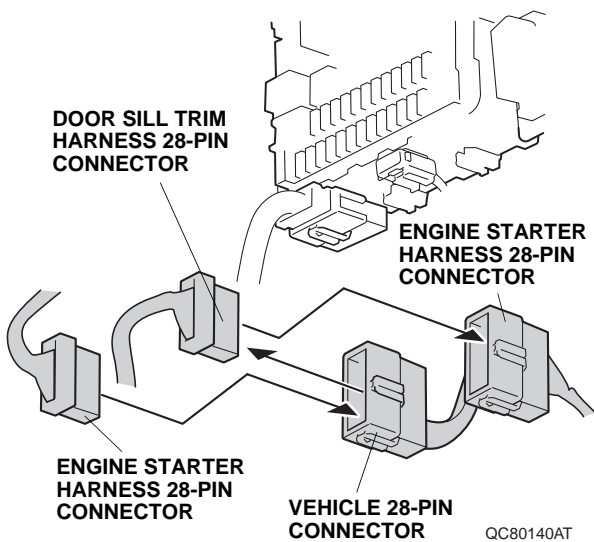

51. Attach the connectors and clip on the engine starter harness as shown. Go to step 58.

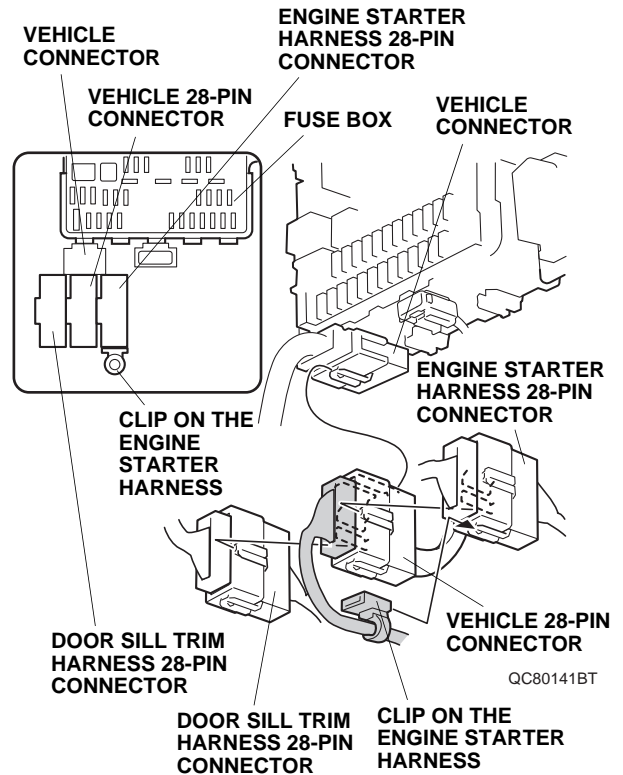

52. Without moonroof model: Plug the engine starter harness 28-pin connector into the engine starter harness 28-pin connector as shown.

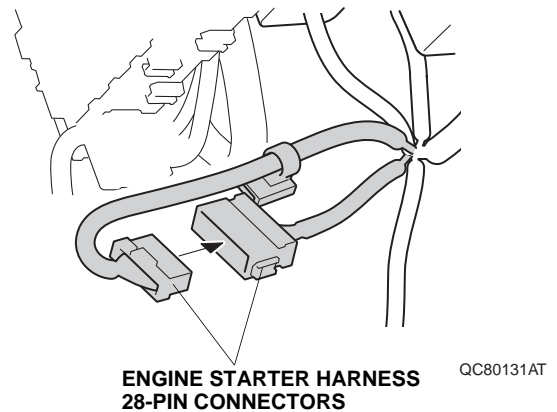

53. Attach the connectors and clip on the engine starter harness as shown. Go to step 58.

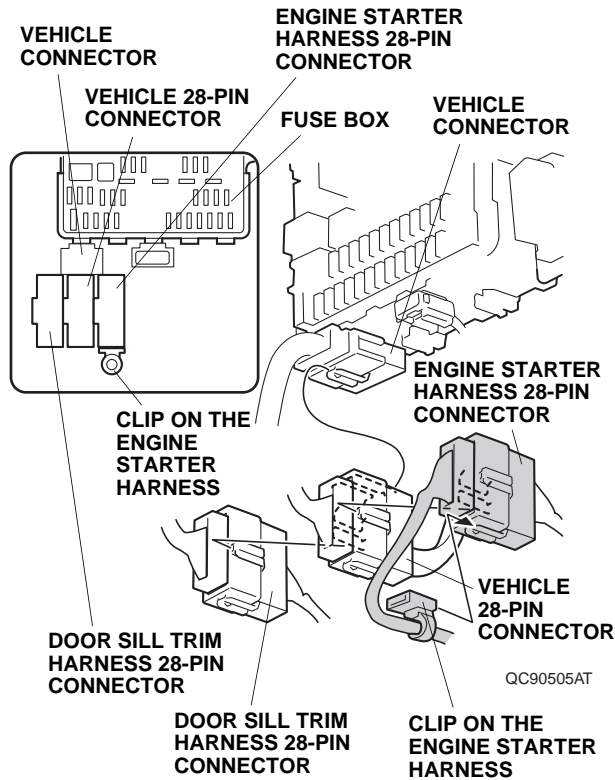

Without Accessory Door Sill Trim

54. With moonroof model: Unplug the vehicle 28-pin connector, and plug it into the engine starter harness 28-pin connector. Plug the remaining engine starter harness 28-pin connector into the vehicle 28-pin connector. Go to step 56.

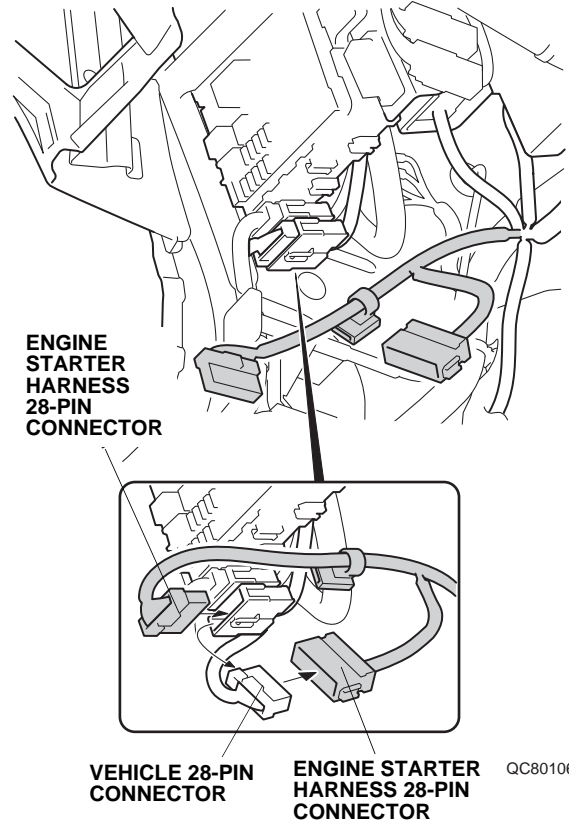

55. Without moonroof model: Plug the engine starter harness 28-pin connector into the engine starter harness 28-pin connector as shown.

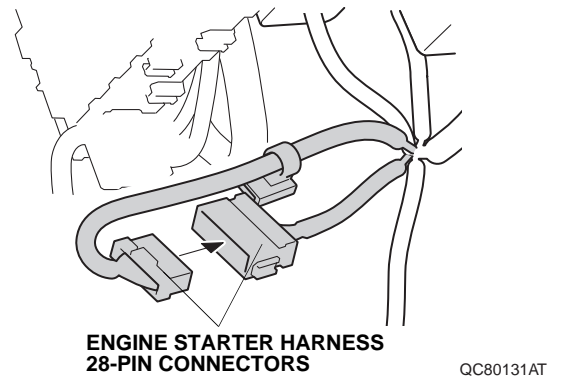

56. Attach the engine starter harness 28-pin connector to the vehicle 28-pin connector as shown.

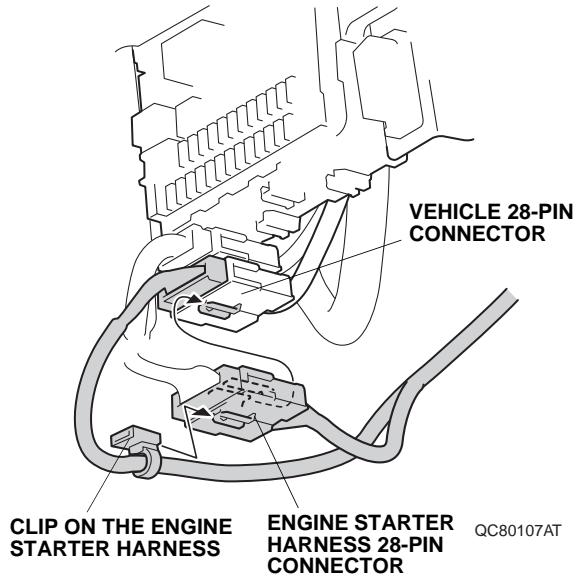

57. Attach the clip on the engine starter harness to the engine starter harness 28-pin connector.
58. Unplug the vehicle 2-pin connector. Remove the vehicle 2-pin connector from the vehicle 14-pin connector as shown.

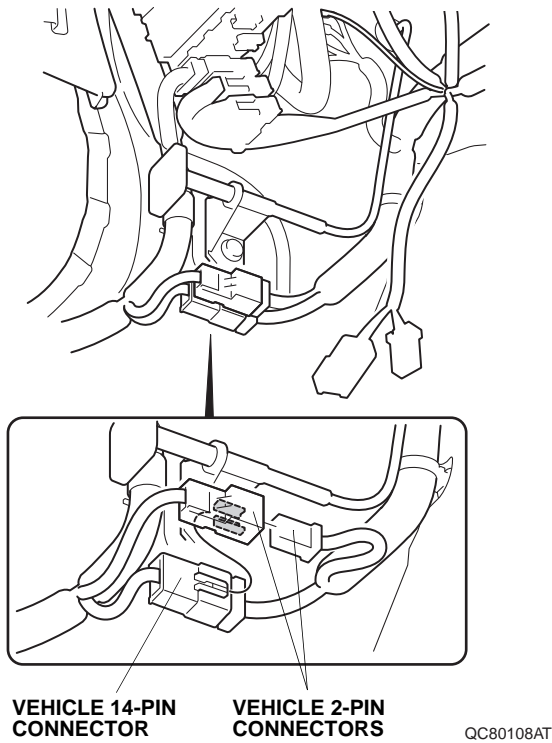

59. Unplug the vehicle 14-pin connector, and plug it into the engine starter harness 14-pin connector. Plug the remaining engine starter harness 14-pin connector into the vehicle 14-pin connector.

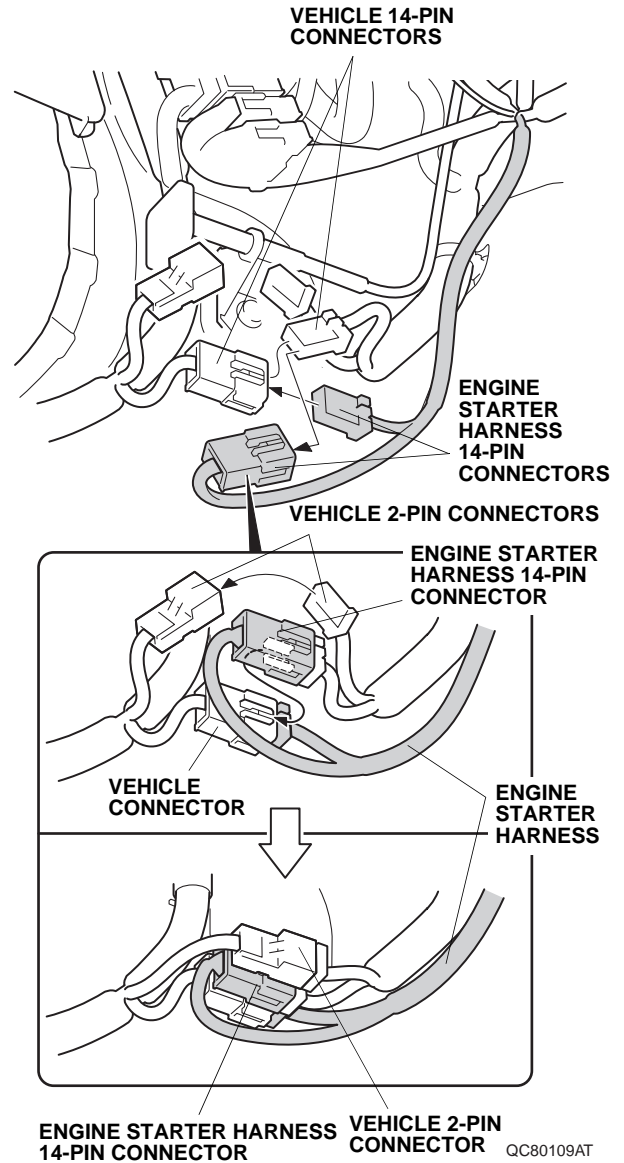

60. Attach the engine starter harness 14-pin connector to the vehicle connector as shown.
61. Plug the vehicle 2-pin connector into the vehicle 2-pin connector, and attach the vehicle 2-pin connector to the engine starter harness 14-pin connector as shown.

62. Route the antenna cable as shown. Using two wire ties, secure the antenna cable to the vehicle harness and engine starter harness.

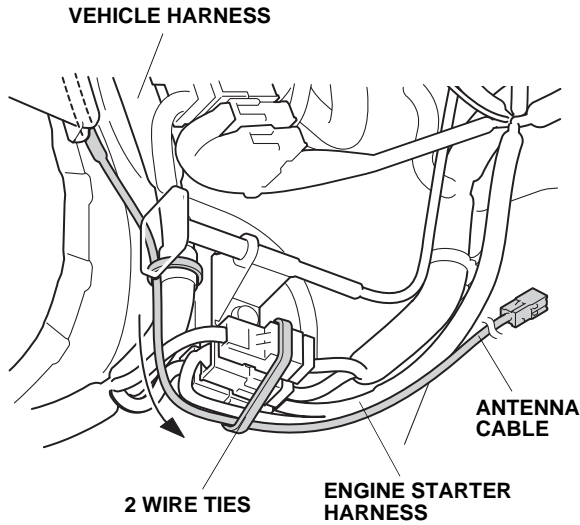

63. Plug the antenna cable connector into the control unit as shown.

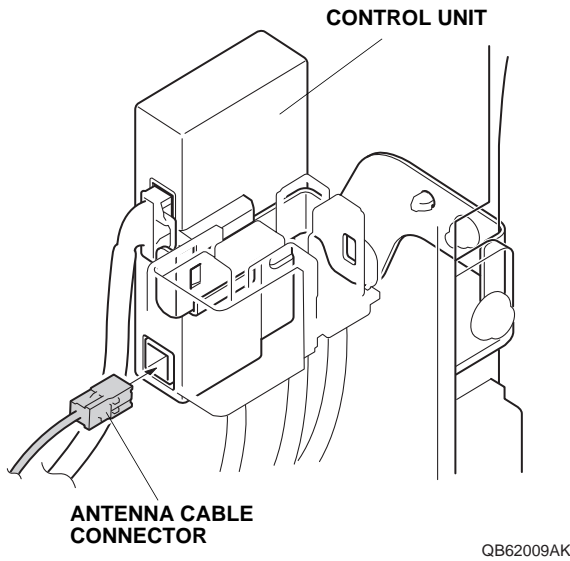

64. Using one wire tie, secure the antenna cable and engine starter harness to the vehicle harness.

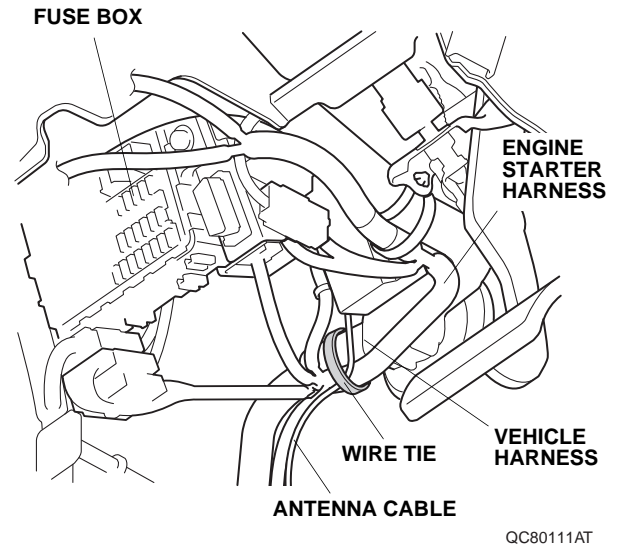

65. Bundle up the excess antenna cable as shown.

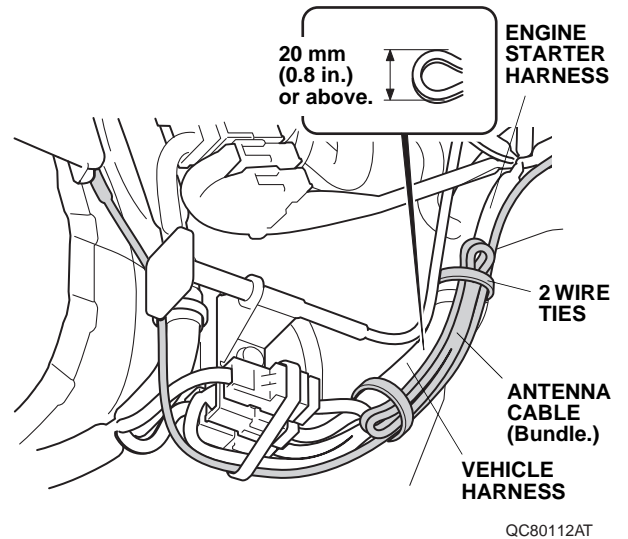

66. Using two wire ties, secure the antenna cable and engine starter harness to the vehicle harness.

67. Using one wire tie, secure the engine starter harness to the vehicle harness.

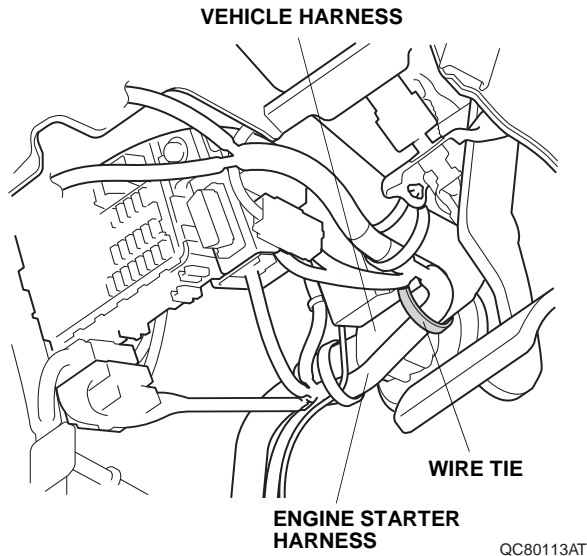

68. Route the engine starter harness along the vehicle harness as shown.

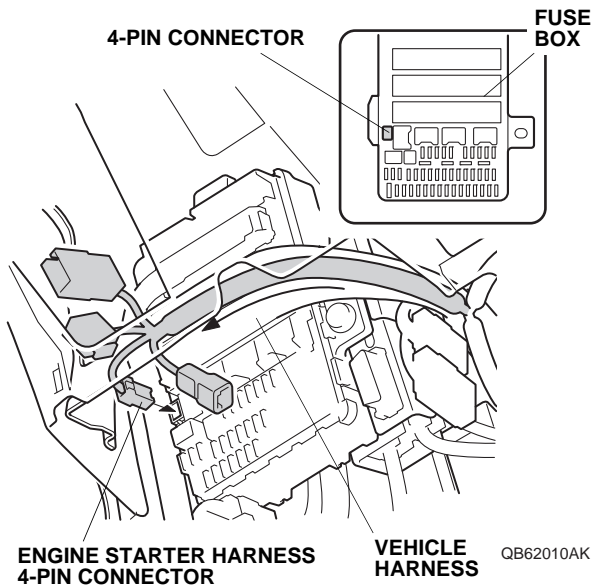

69. Plug the engine starter harness 4-pin connector into the fuse box.

NOTE: If another accessory 4-pin connector is plugged into the fuse box, unplug the 4-pin connector from the fuse box, then plug the engine starter harness 4-pin connector into the fuse box. Plug another accessory 4-pin connector into the engine starter harness 4-pin connector.

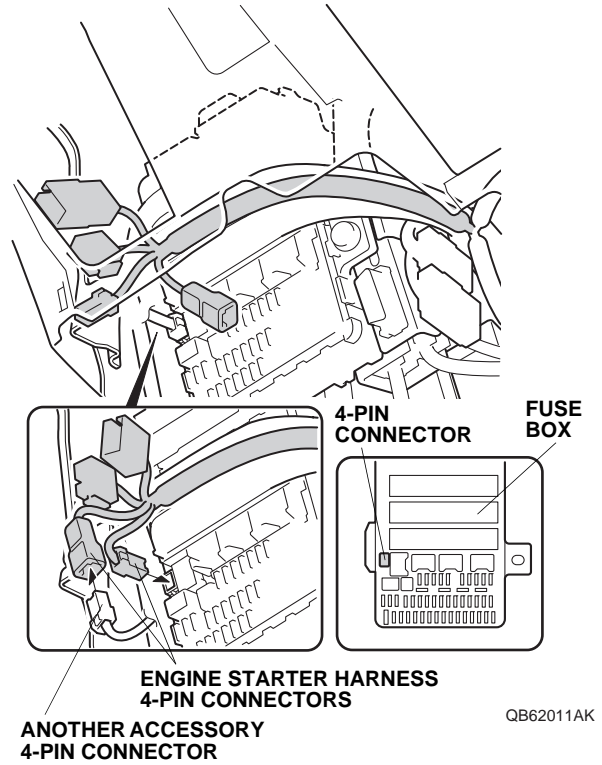

70. Using one wire tie, secure the engine starter harness 4-pin connector to the vehicle harness.

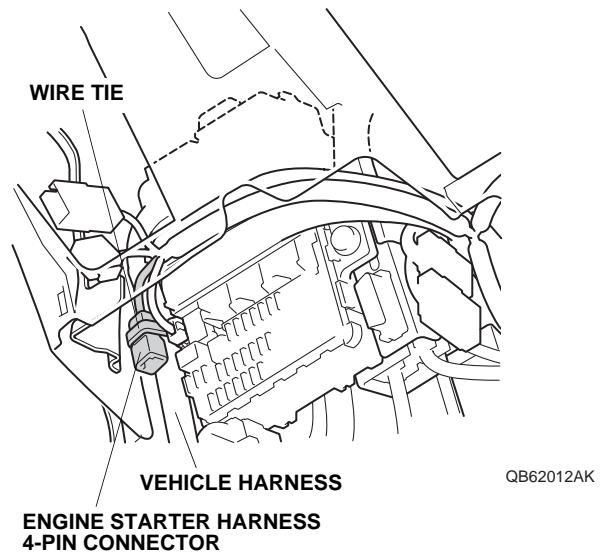

71. Using scissors, cut one urethane tape to the measurements shown. Wrap the cut urethane tape around the engine starter harness 5-pin connector as shown.

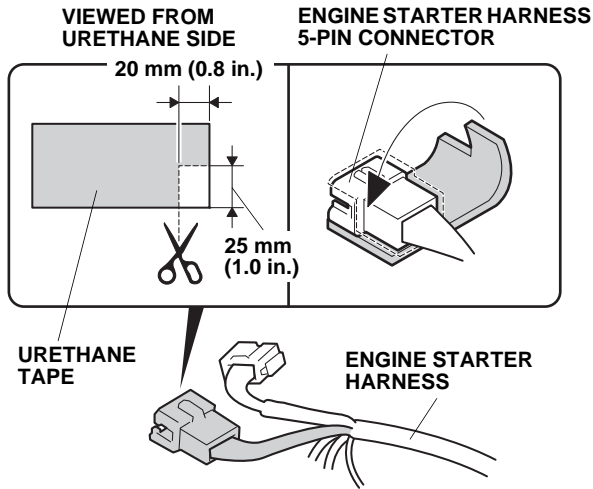

Q002507AK

72. Unplug the vehicle 5-pin connector from the fuse box. Plug the engine starter harness 5-pin connector into the fuse box 5-pin connector. Plug the vehicle 5-pin connector into the engine starter harness 5-pin connector.

NOTICE: Make sure the engine starter harness 5-pin connector is securely connected to the fuse box 5-pin connector. A loose connection can cause the engine to stall.

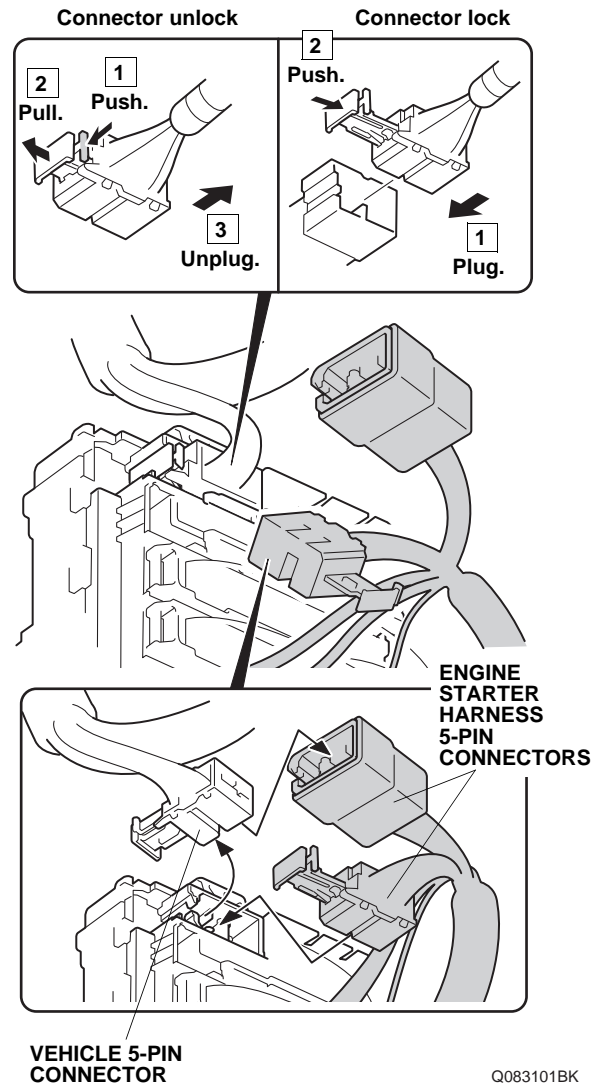

Q083101BK

73. Using one long wire tie, secure the engine starter harness 5-pin connector to the vehicle panel.

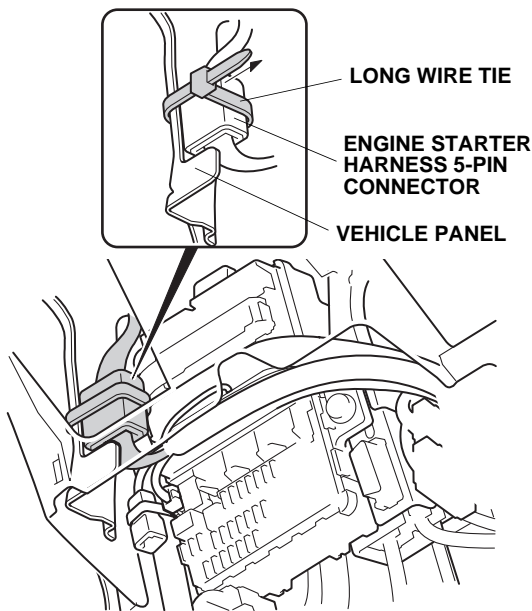

QC80114AT

74. Unplug the vehicle 2-pin and 16-pin connectors, and plug them into the engine starter harness 2-pin and 16-pin connectors. Plug the engine starter harness 16-pin and 2-pin connectors into the vehicle 16-pin and 2-pin connectors.

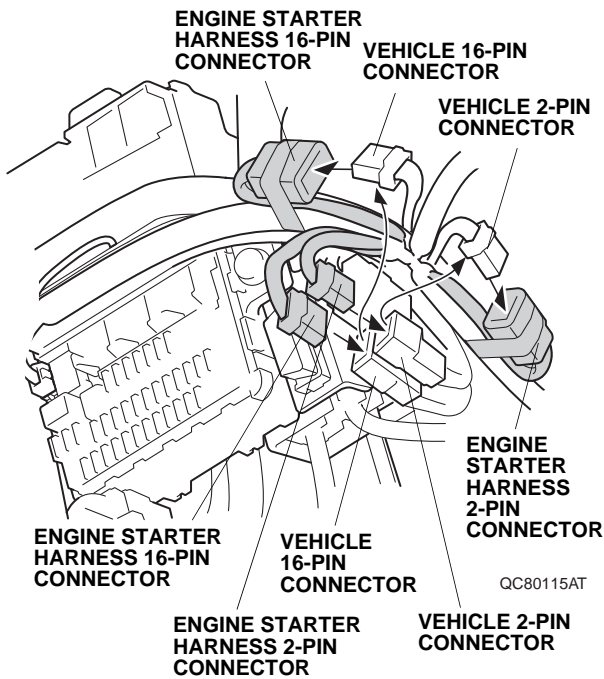

QC80115AT

75. Using one long wire tie, secure the engine starter harness 16-pin connector to the vehicle harness.

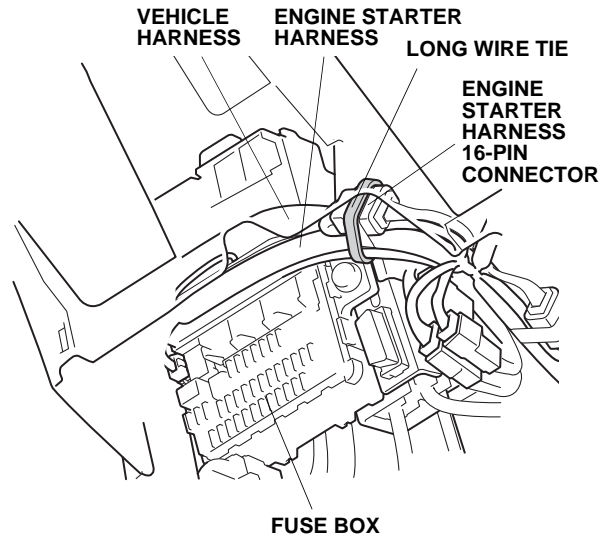

QC80116AT

76. Route the engine starter harness as shown. Using one wire tie, secure the engine starter harness at the white tape to the hole in the dashboard panel.

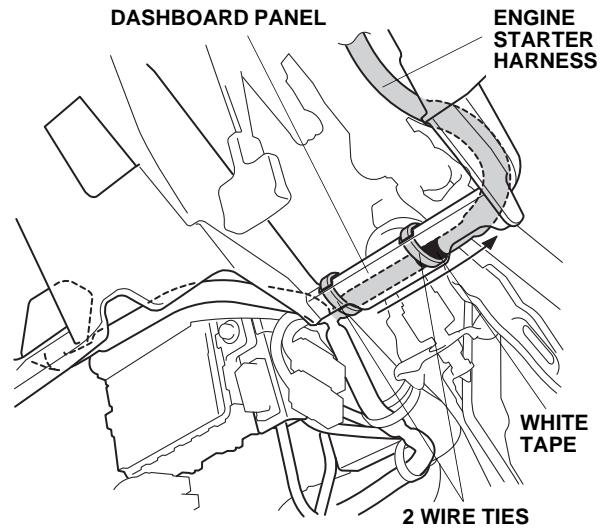

Q090104BK

77. Using one wire tie, secure the engine starter harness to the hole in the dashboard panel.

- If the vehicle you are working on is a 2-door model, go to step 85; otherwise, continue with step 78.

78. Remove the vehicle unit (three bolts).

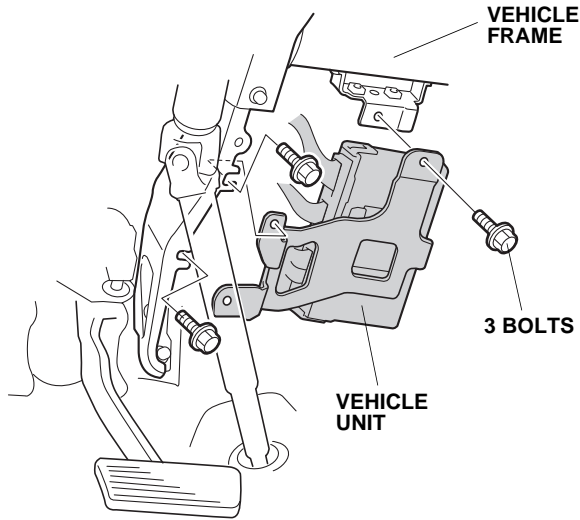

QC80117AT

79. Using isopropyl alcohol on a shop towel, thoroughly clean the area where the urethane tape will attach.

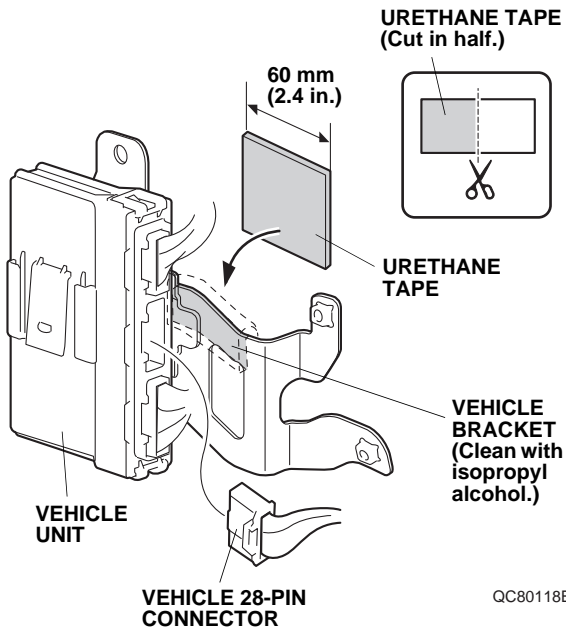

QC80118BT

80. Using scissors, cut one urethane tape in half. Attach a half of urethane tape to the vehicle bracket.

81. Unplug the vehicle 28-pin connector from the vehicle unit.

82. Plug the vehicle 28-pin connector into the engine starter harness 28-pin connector. Plug the engine starter harness 28-pin connector into the vehicle unit.

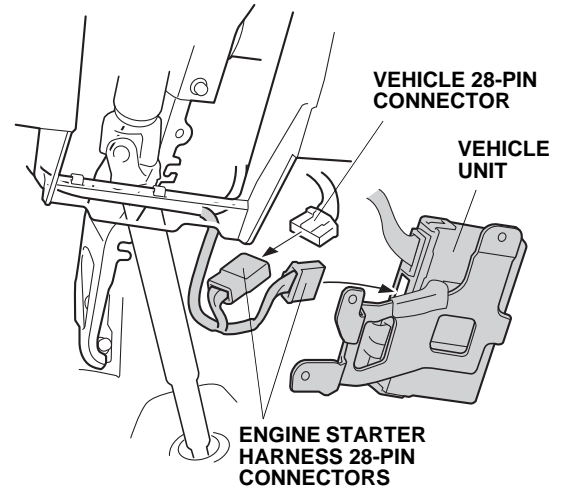

QC80119AT

83. Reinstall the vehicle unit.

84. Using one long wire tie, secure the engine starter harness 28-pin connector to the vehicle harness. Go to step 91.

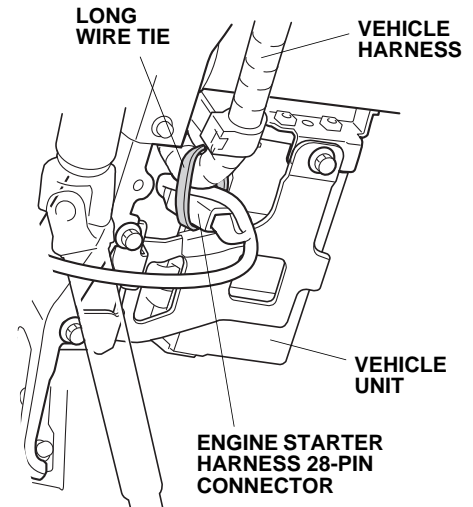

QC80120AT

85. Remove the vehicle unit (three bolts and two vehicle connectors).

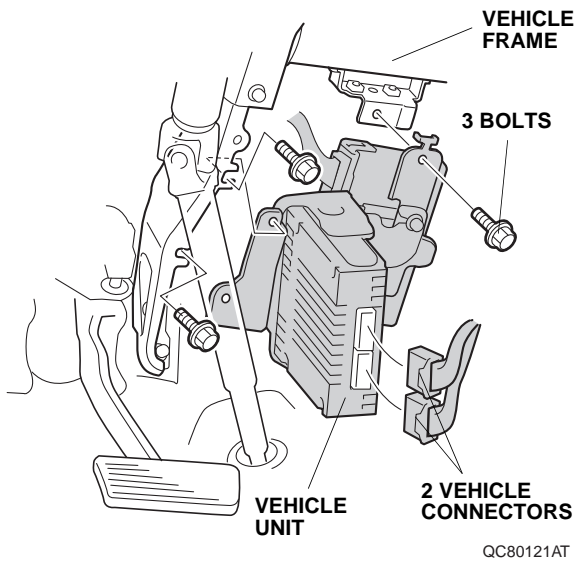

86. Using isopropyl alcohol on a shop towel, thoroughly clean the area where the urethane tape will attach.

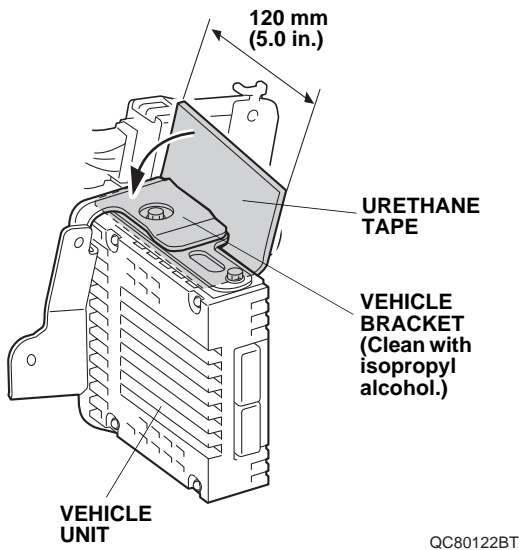

87. Attach the urethane tape to the vehicle bracket.

88. Unplug the vehicle 28-pin connector from the vehicle unit, and plug it into the engine starter harness 28-pin connector. Plug the engine starter harness 28-pin connector into the vehicle unit.

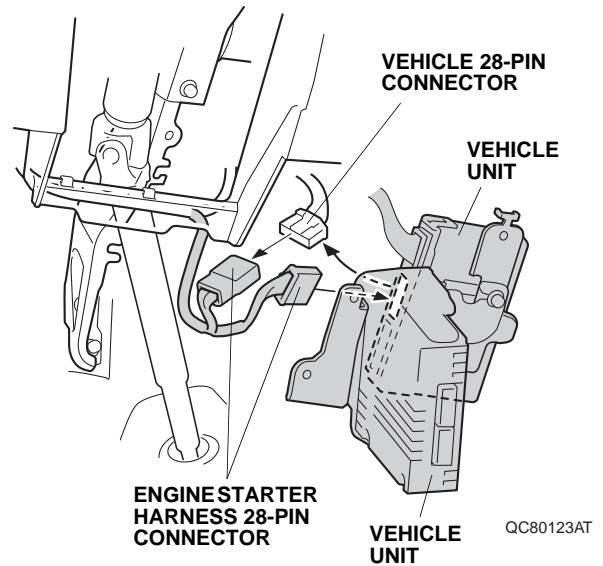

89. Reinstall the vehicle unit.
90. Using one long wire tie, secure the engine starter harness 28-pin connector to the vehicle harness.

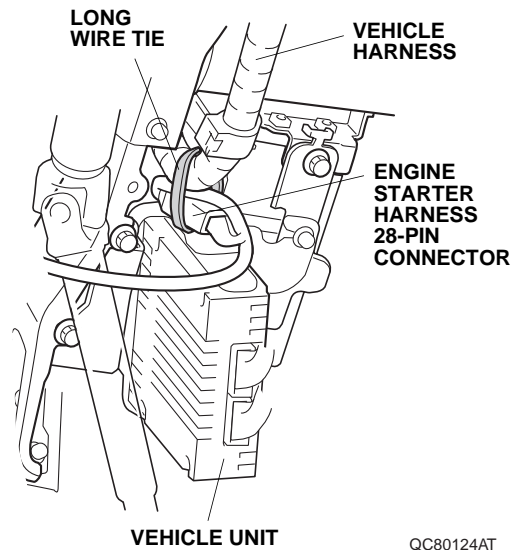

91. Route the 12-pin/10-pin connector ends of the engine starter harness to the steering column.

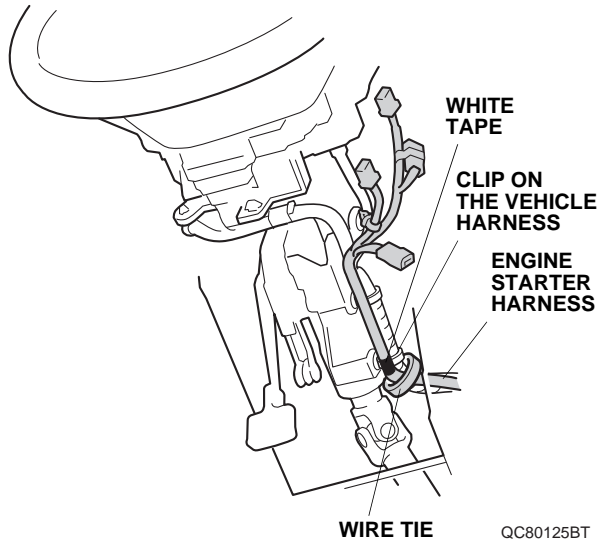

92. Align the white tape on the engine starter harness with the clip on the vehicle harness, and secure the engine starter harness to the vehicle harness using one wire tie.

93. Route the engine starter harness 10-pin connectors as shown. Unplug the vehicle 10-pin connector, and remove the clip on the vehicle harness. Plug the vehicle 10-pin connector into the engine starter harness 10-pin connector. Plug the remaining engine starter harness 10-pin connector into the wiper switch.

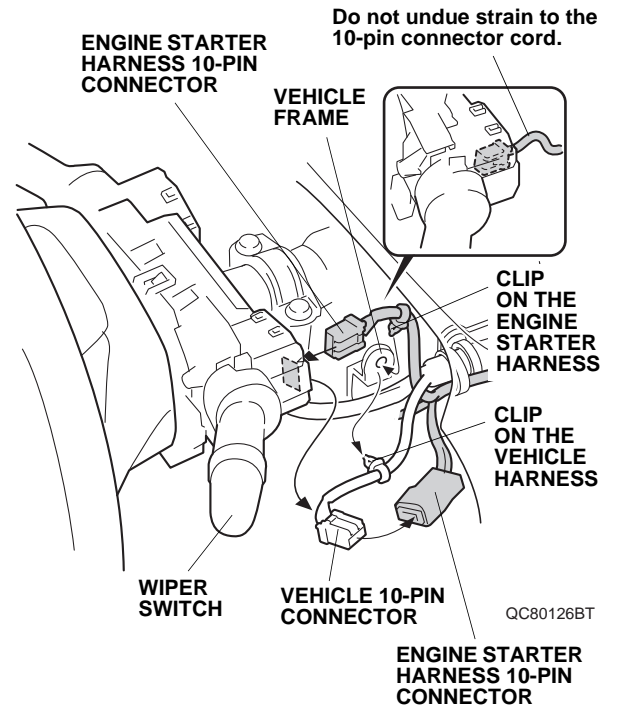

94. Secure the clip on the engine starter harness to the vehicle frame as shown.

95. Using a diagonal cutters, remove the clip from the vehicle harness. Do not damage the vehicle harness.

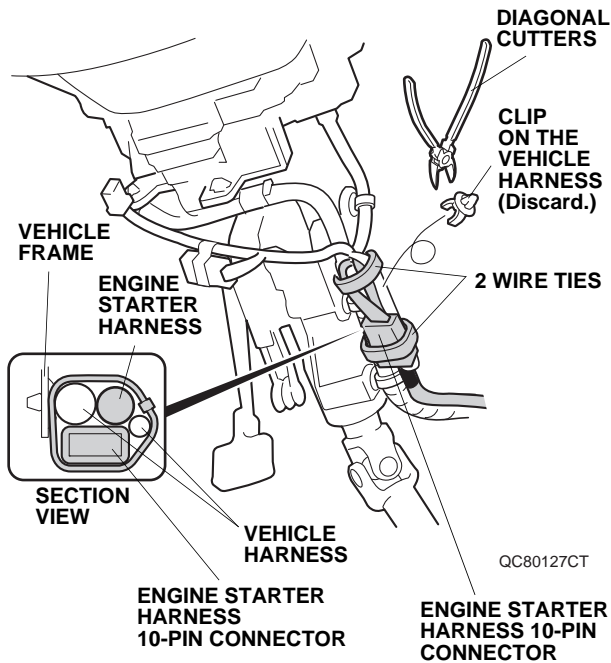

96. Secure the engine starter harness 10-pin connector and engine starter harness to the vehicle harness with two wire ties.
97. Route the engine starter harness 12-pin connectors as shown. Unplug the vehicle 12-pin connector, and plug it into the engine starter harness 12-pin connector. Plug the remaining engine starter harness 12-pin connector into the combination light switch.

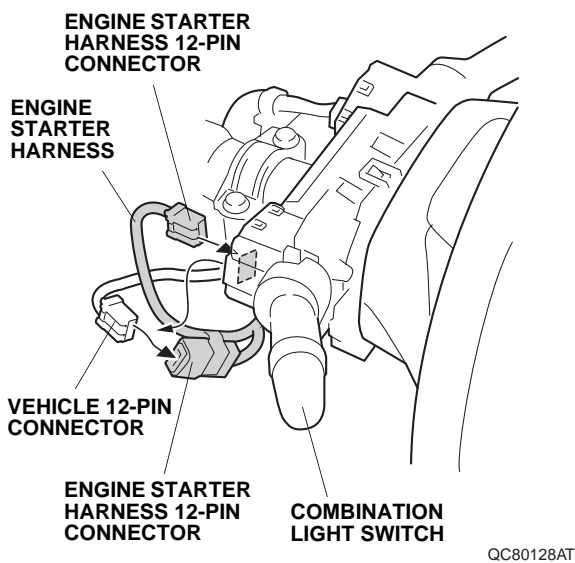

98. Align the white tape on the engine starter harness with the vehicle clip, and secure the engine starter harness and engine starter harness 12-pin connector to the vehicle harness with two wire ties. Do not secure it to the SRS harness.
- NOTE: Make sure that the connectors and harness are not pinched, or are not interfering with the steering wheel when it is moved for adjustment.

Do not undue strain to the 12-pin connector cord.

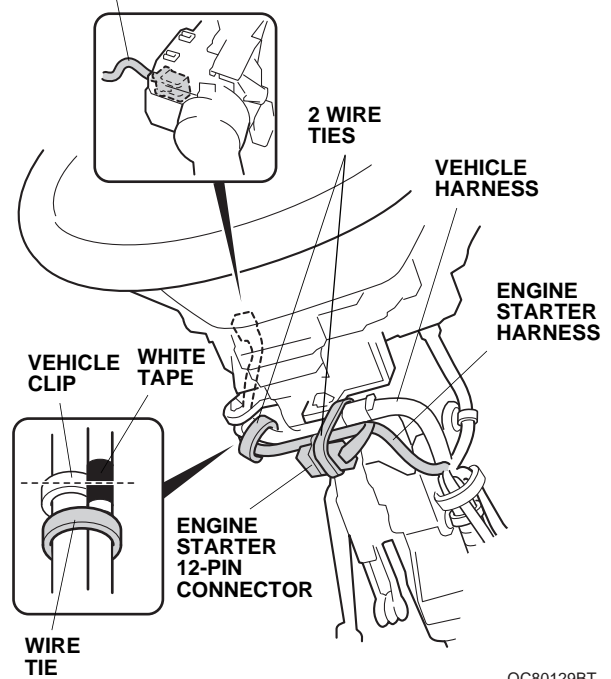

99. Using isopropyl alcohol on a shop towel, clean the area where the urethane tape will attach.

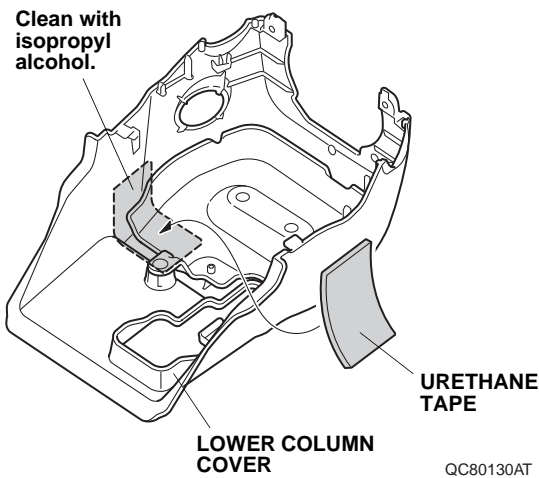

100. Attach the urethane tape to the lower column cover as shown.

101. Using isopropyl alcohol on a shop towel, clean the hood where the caution label will attach.

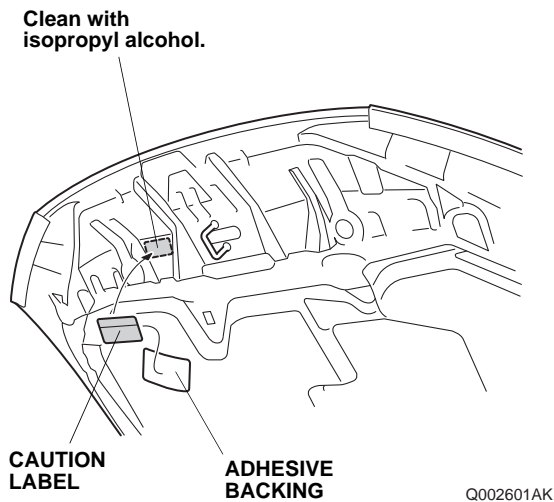

102. Attach the caution label to the hood in the area shown.

103. Check that all wire harnesses are routed properly and all connectors are plugged in.
104. Check the overlap between the headliner and the driver's A-pillar trim. Refer to the Service Manual. If necessary, adjust the overlap.
105. Reinstall all removed parts.
106. Reconnect the negative cable to the battery.
107. Press and hold the radio power button for two seconds to restore the radio and navi (if equipped) system functions.
108. Reset the clock.
109. Restore the systems back to normal operation as described in the Service Manual if necessary.
110. Make sure if you can open the trunk using the trunk release button on the keyless access remote when the trunk opener is UNLOCK.
111. Make sure if you cannot open the trunk using the trunk release button on the keyless access remote when the trunk opener is LOCK.
112. Perform the "REMOTE ENGINE STARTER REGISTRATION" and the "FUNCTION CHECK".

REMOTE ENGINE STARTER REGISTRATION

NOTE: Register after making sure the HDS has been upgraded to the latest version as described in the Service News.

1. Acquire the PCM Code from the Interactive Network.

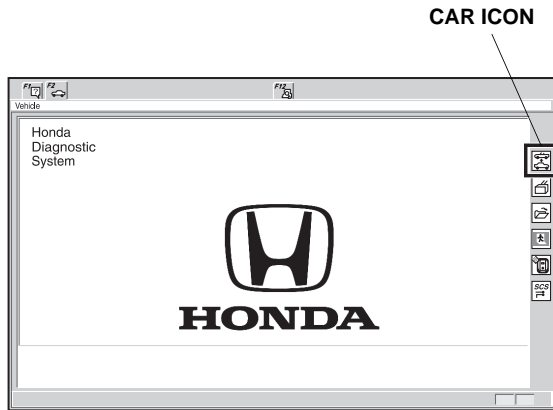

QC31909AC

2. Connect the HDS/MVCI tester to the OBD II data link connector, then press the engine switch to ON.
3. Start the HDS, and click the car icon.
4. Input the VIN and other required information into the HDS, then click the check button.

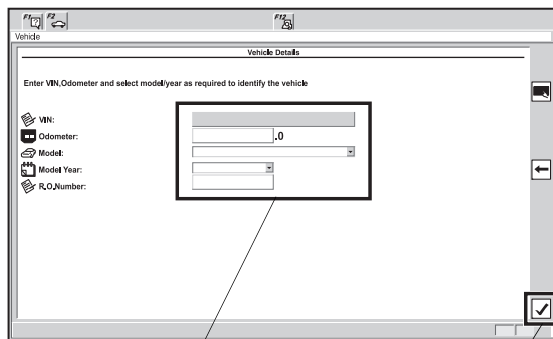

Input the VIN and other required information.

CHECK BUTTON

QB32102BH

5. Select **Honda Systems**, then click the check button.

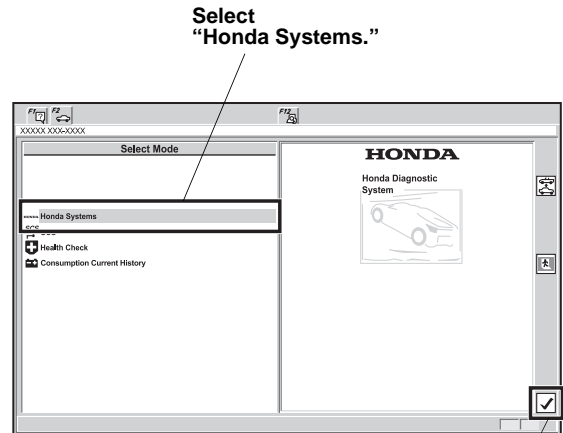

CHECK BUTTON

QB32103AH

6. Select **R/C ENG STARTER** and click the check button.

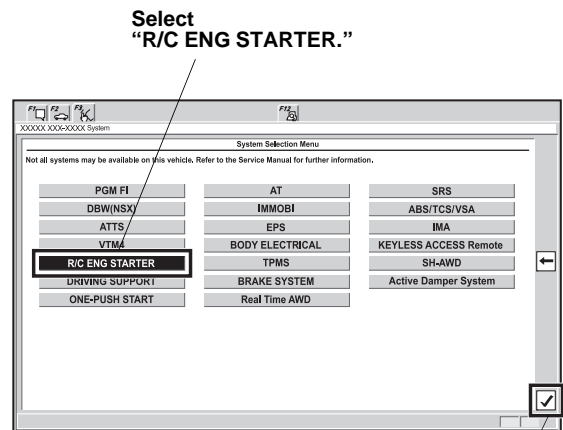

CHECK BUTTON

QB32104AH

7. Select **REGISTER REMOTE CONTROL ENGINE STARTER UNIT**, then click the check button.

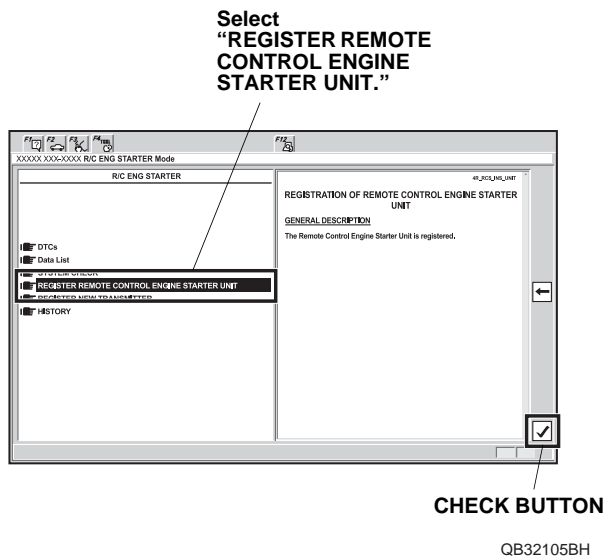

8. The following message will display: **Obtain PCM-code (IMMOBILIZER PCM CODE) from iN. This vehicle's VIN will be required to obtain the password. (USA)** Click the check button.

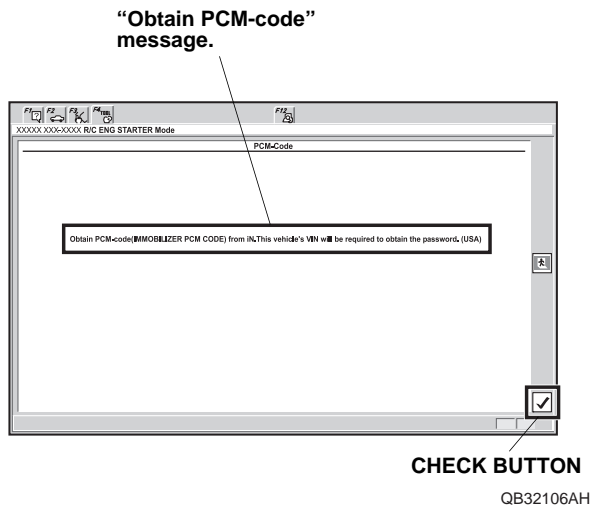

9. Input the PCM-code, then click the check button.
NOTE: To ensure security, the PCM-code (password) is changed everyday, so it is impossible to register the remote control engine starter if the dates of the PCM-code acquisition and registration are different. The date of the HDS/MVCI tester should also be the same.

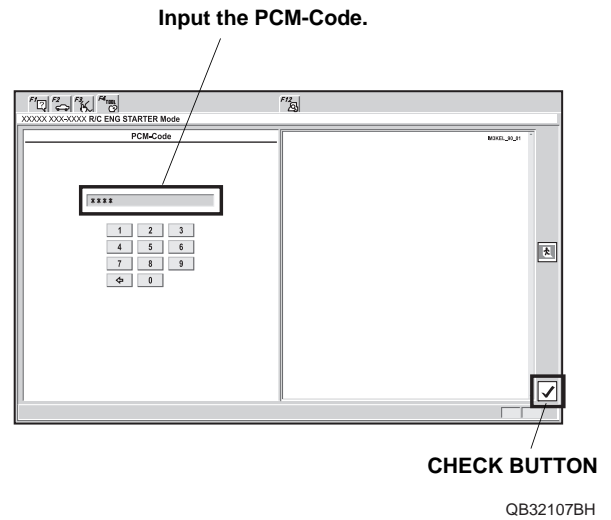

10. The following message will display: **The registration of the Remote Control Engine Starter Unit has been completed.** Press the engine switch to OFF.

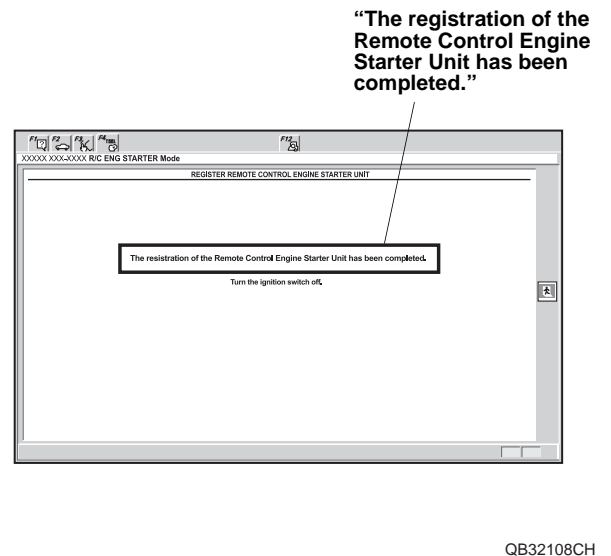

11. The following message will display: **Check that engine can be started by the Transmitter.** Click the check button.

“Check that engine can be started by the Transmitter.”

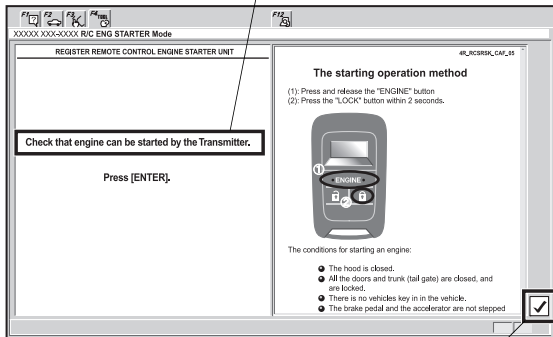

CHECK BUTTON QB32109CH

12. Clear the DTC, then disconnect the HDS/MVCI.

FUNCTION CHECK

Operating Conditions

- The hood is closed
- The shift lever is in park
- Press the engine switch to OFF and the key is outside the vehicle
- All doors and trunk lid closed and locked

Inspection

1. Press the engine/command button on the transmitter and release, within 2 seconds, press the lock/start button on the transmitter.

The engine should start if all operating conditions are met.

Does the engine start?

Yes - Operation is normal.
No:
<ul style="list-style-type: none"> • Make sure all "Operating Conditions" are met. • Check the engine starter harness connections. • Connect the HDS/MVCI and check for an indicated failure. (Refer to the appropriate Service Manual for details.)

2. Press the engine/command button on the transmitter and release, within 2 seconds, press the unlock/stop button. The engine should stop.

Does the engine stop?

Yes - Operation is normal.
No - Check the engine starter harness connections.

3. After the engine has stopped, start the engine again, and check that the engine stops after each of the following conditions:

NOTE: After each test the ignition key must be cycled, or the driver's door must be opened and closed.

- Move the shift lever out of the P position.
- Unlock or open the doors or the trunk lid.
- Open the hood.
- Press the engine switch.
- Press on the brake pedal.

Does the engine stop after each of these tests?

Yes - Operation is normal.
No - Check the engine starter harness connections.

4. Check that the power windows and the moonroof do not function, and the shift lever does not move to any position when the engine is started with the transmitter.
5. Check that the engine does not start under "Operating Conditions" with the key left inside the vehicle.
6. Start the engine again, press the engine/command button on the transmitter two times, and check the vehicle condition on the display.

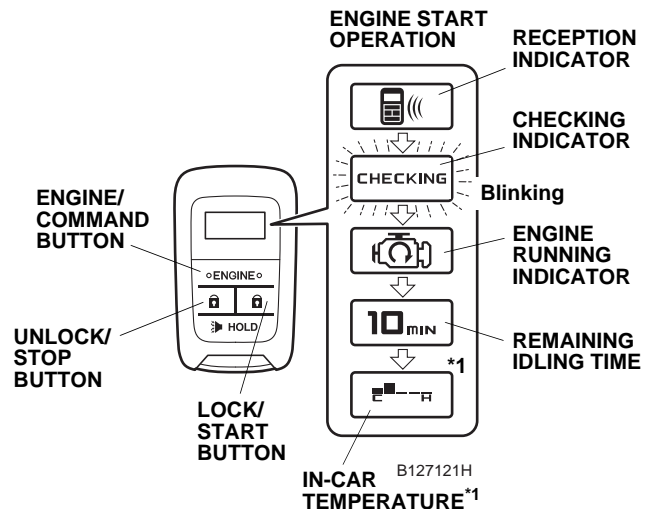

*1 Only on vehicles equipped with the automatic climate control. This indicator is displayed for some vehicles among them.

7. Check the operation of the transmitter when the vehicle is 120 m (400 ft.) away and in direct sight.
8. Press the unlock/stop button on the transmitter and verify that the doors unlock. Press the lock/start button, and verify that the doors lock.
9. Check that the engine can start by the vehicle key and that the wiper and the headlight can be operated normally.